





Drawing No.	Rev.	Date	Page
EL-B02L0300-DSA-D2410W	B	2018/11/26	1/8

# APPROVAL SHEET

Part No: **EL-B02L0300-DSA-D2410W**

NOTE :  
**WIDE-BAND**

MAKER			CUSTOMER	
				
R&D	QA	Sales	Checked	Approved
				

Prepared	Checked	Approved
Rachel Lee	Evan Chang	Kenneth Wu

Drawing No.	Rev.	Date	Page
EL-B02L0300-DSA-D2410W	B	2018/11/26	2/8

**Description of P/N No.**

**EL - B02L0300 - DSA - D2410W**

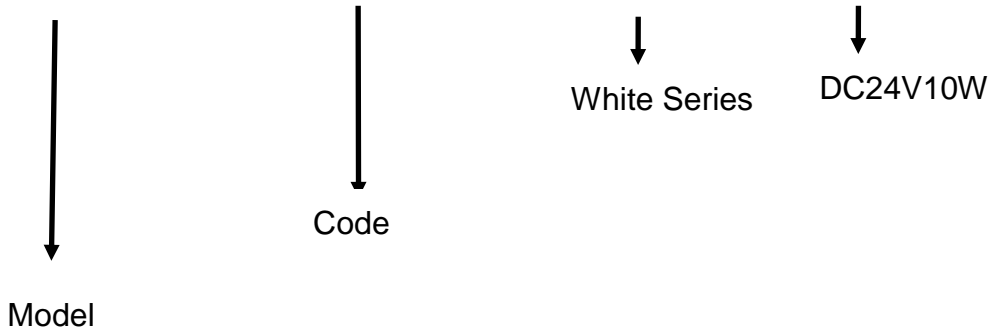

**Description of Lot.**

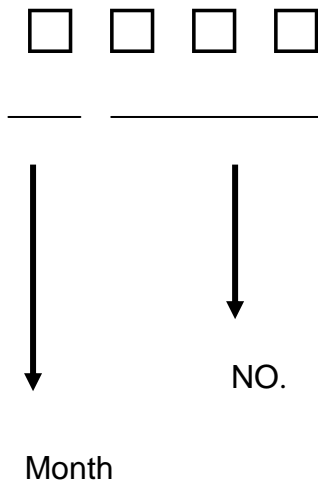

**Solidlite Corp.** 

P/N : \_\_\_\_\_

Lot : \_\_\_\_\_

Date: \_\_\_\_\_ . Rank: \_\_\_\_\_

Q'ty : \_\_\_\_\_ . QA : \_\_\_\_\_

Drawing No.	Rev.	Date	Page
EL-B02L0300-DSA-D2410W	B	2018/11/26	3/8

## Specification for Approval

**Product :** LED FLAT PANEL

**Part Number :** EL-B02L0300-DSA-D2410W

### Applications

**Area:** Indoor use only

**Purpose:**

Plant Growing Lighting , Office Lighting , Meeting Room Lighting , Shop Lighting ,  
Classroom Lighting , Factory Lighting , .....

### Product Overview

※ Aluminum heat-sink base can dissipate more heat and lead to a longer life span.

### Specification ※For Plant Factory use only.

※Remember not to use the device underwater.

**Outline Dimension:** (L)300 (±5mm)mm (W) 100 (±4mm)mm (H) 15.7 (±0.3mm)mm

**Input Voltage /Current :** DC24V/400mA

**Operating Temperature / Relative Humidity:** 0°C~35°C / 20%~80%RH  
(Warranty Conditions)

**Storage Temp Range / Relative Humidity:** -20°C ~ 60°C / 20% ~ 80 %RH

**Heat-Sink Surface Temp:** <60 °C

**Life Expectancy of Driver :** 40000hrs

**Life Expectancy of LEDs :**40000hrs

### Safety warning

**Cautions:**

Don't drop the luminaire on the ground since the luminaire will be damaged

Don't expose this product at the high temperature and high humidity environment

### Warranty

Warranty 1years.

Should not have an adverse early.

Within one years, must be greater than the specification brightness light efficiency of 70%.



**Waterproof and dust tight IP66\***

\*Claims and Test Results:The claims are mainly based on results from tests conducted by SGS.(Report No.:OC-2016-300041)

## Chromaticity Coordinate

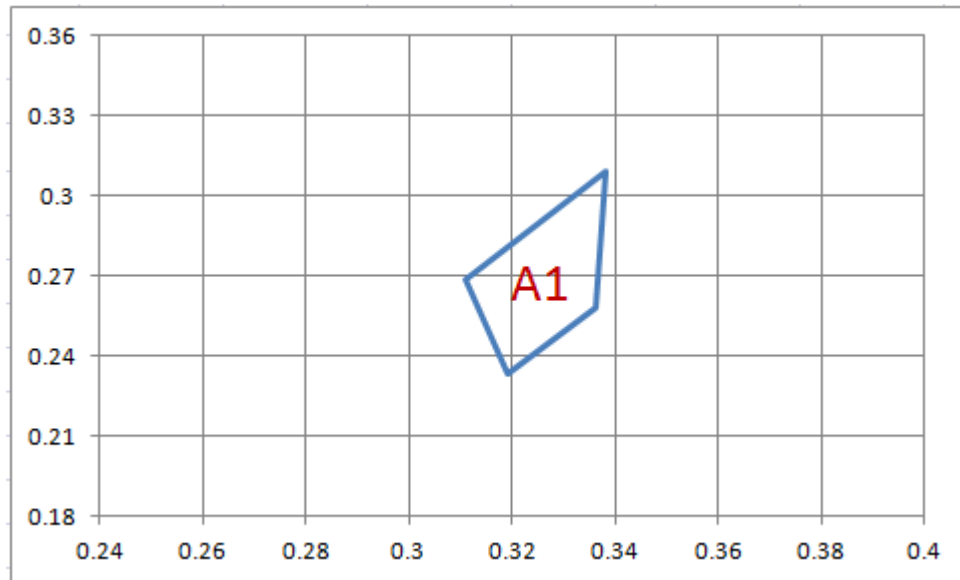

CIE X./Y :

A1 --- (0.311, 0.269) (0.338, 0.309) (0.336, 0.258) (0.319, 0.233)

## Electronic Charateristic

Absolute Maximum Ratings at  $T_a=25^{\circ}\text{C}$

Item	EL-B02L0300-DSA-D2410W
LED Quantity	84pcs
DC V input	24V
DC I input	400mA
Power Dissipation	10w
Heat-Sink Spec.	Aluminum
PCB Spec.	FR4
L/W/H	300mm ( $\pm 5\text{mm}$ )/100mm( $\pm 4\text{mm}$ )/15.7mm( $\pm 0.3\text{mm}$ )
Net weight	300g $\pm$ 50g

### Product size & Photo

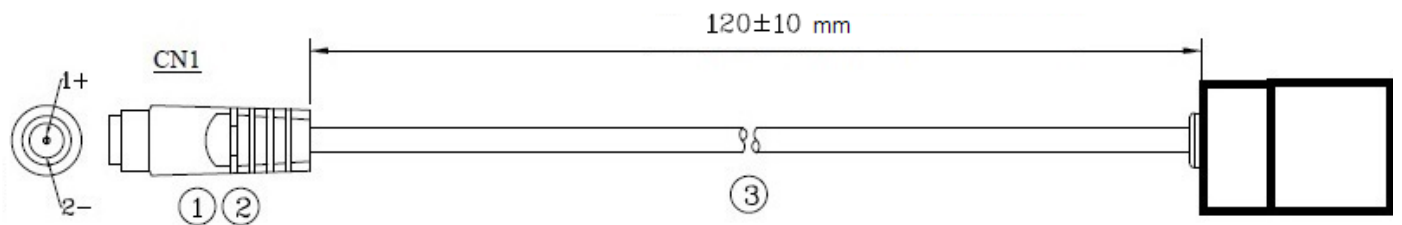
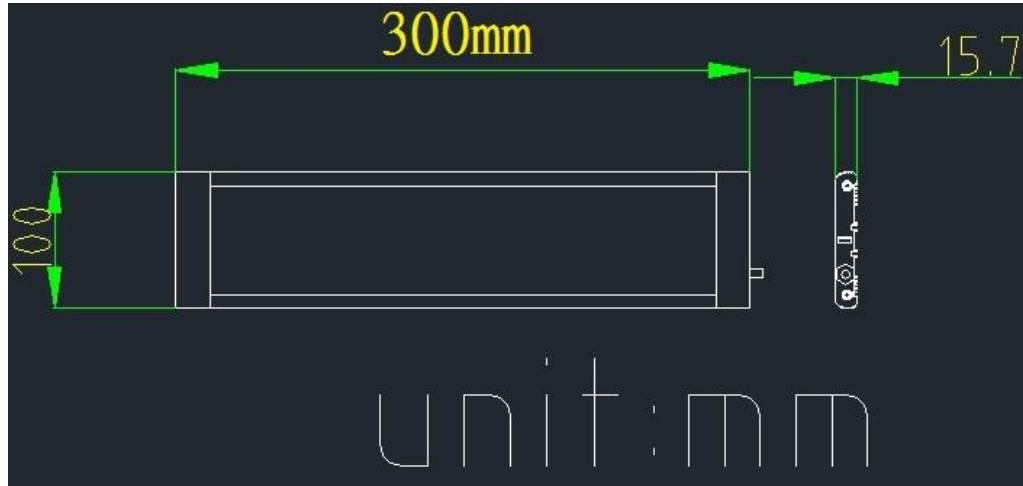

3	CABLE	UL2464#24*2C(STD) OD:3.5mm	1	BLACK(0
2	PLASTIC	PVC45P/80°C		BLACK(0
1	DC JACK	(5.5*2.1mm)DC-0236-3	1	鍍度金泉
NO	PART NAME	PART NO	Q'TY	COLOR



Drawing No.	Rev.	Date	Page
EL-B02L0300-DSA-D2410W	B	2018/11/26	6/8

## Typical Internal Equivalent Circuits

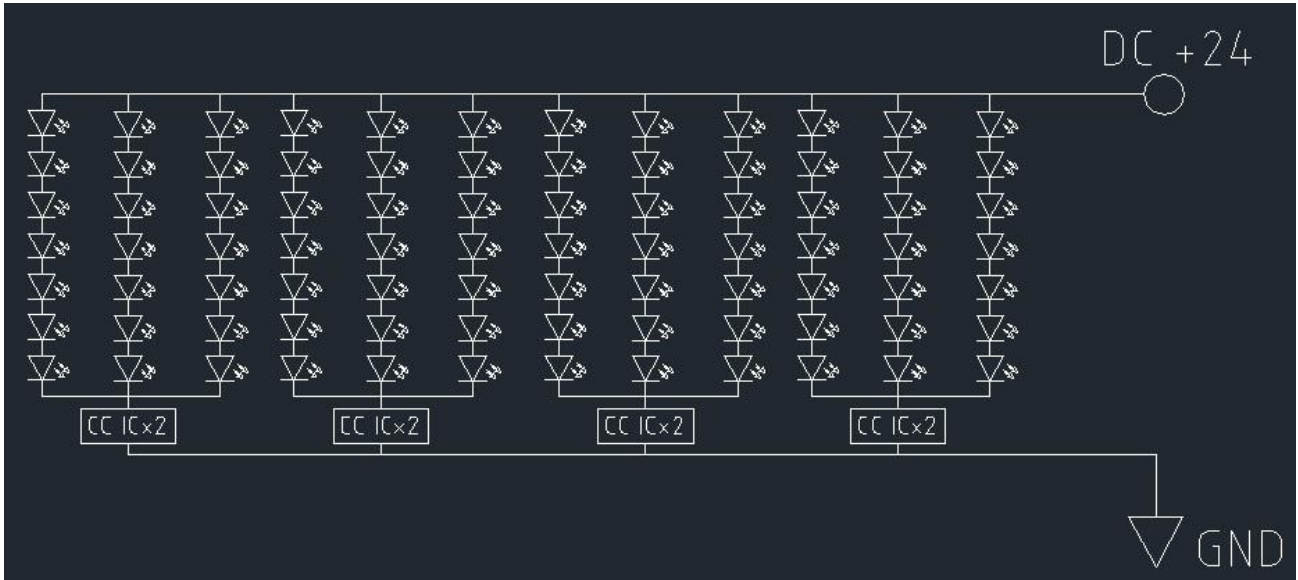

## Label Format

<b>SOLIDLITE</b>	<b>EL-B02L0300-DSA-D2410</b>	輸入電圧DC24V <b>1531</b>
詮興開發科技股份有限公司	LED Flat Panel <b>2410W</b> LED平板燈 <b>2410W</b>	消耗功率:10W
		輸入電流: <b>MADE IN TAIWAN</b>

Drawing No.	Rev.	Date	Page
EL-B02L0300-DSA-D2410W	B	2018/08/22	7/8

## Optical Characteristic

Item	EL-B02L0300-DSA-D2410W
Viewing Angle	65°(±10%)
μMol/s*m <sup>2</sup> (The center of the amount of survey)	50±20% @ 30cm(center) (without Linear fresnel film)
Light recipe	DSA
CRI	>80

Drawing No.	Rev.	Date	Page
EL-B02L0300-DSA-D2410W	B	2018/08/22	8/8

**Fitting Part**



**Use the illustration:**

