





Drawing No.	*Rev.	Date	Page
BF5H45G-YLR-050mA	A	2018/08/09	1/3

# APPROVAL SHEET

Part No:

BF5H45G-YLR-050mA

NOTE :  
**Green Part**

MAKER			CUSTOMER	
				
R&D	QA	Sales	Checked	Approved
				

Prepared	Checked	Approved
Rachel Lee	Sky Lin	Kenneth Wu

**DESCRIPTION:**

Device Type : BF5H45G-YLR-050mA  
 Dice Material : AlGaAs  
 Light Color : InfraRed 850nm  
 Lens Color : Water Clear  
 Lens Dimension : 5 mm

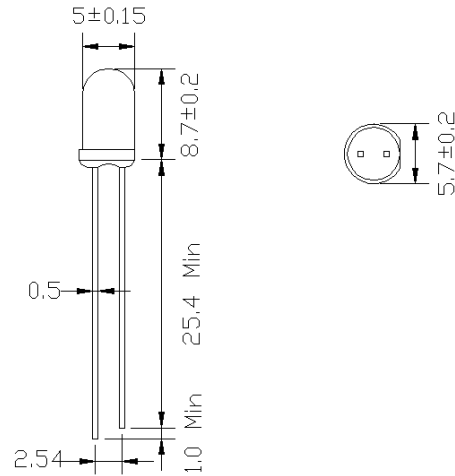

**Absolute Maximum Ratings at Ta=25°C**

Parameter	Max.	Unit
DC Forward Current	60	mA
Reverse Voltage	5	V
Power Dissipation	120	mW
Operating Temperature	Topr : -30 ~ +85	°C
Storage Temperature	Tstr : -40 ~ +100	°C
Solder DIP (MAX. 5 seconds, 1.6mm from body) Temperature 260°C		

**Electrical and Optical Characteristics at Ta=25°C**

Symbol	Description	Test Condition	Min.	Typ.	Max.	Unit
V <sub>F</sub>	Forward Voltage	I <sub>F</sub> = 50mA	-	1.6	2.0	V
I <sub>R</sub>	Reverse Current	V <sub>R</sub> = 5V	-	-	10	μA
λ <sub>P</sub>	Peak Emission Wavelength	I <sub>F</sub> = 50mA	-	850	-	nm
Δλ	Spectral Line Halfwidth	I <sub>F</sub> = 50mA	-	40	-	nm
2θ <sub>1/2</sub>	Viewing Angle	I <sub>F</sub> = 50mA	-	45	-	Deg.
P <sub>o</sub>	Radiant Power	I <sub>F</sub> = 50mA	20	-	35	mW

- Note:
- 1.The lead should be formed up to 5mm from the body of device without forming stress.
  2. Soldering shall be performed after lead forming.
  3. All dimensions are in millimeters

## LED LAMP Technical Data

### Typical Optical-Electrical Characteristic Curves

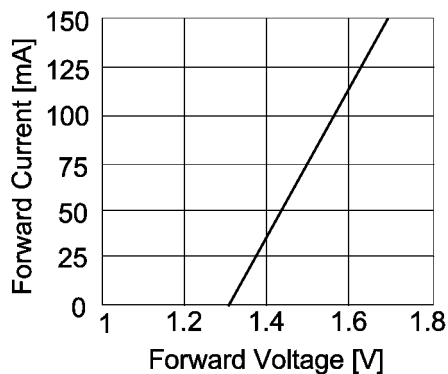

**Forward Current  
Vs. Forward Voltage**

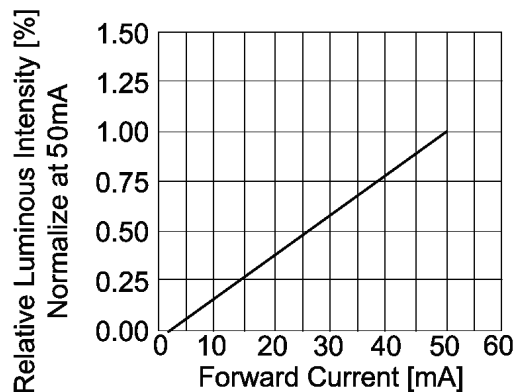

**Luminous Intensity  
Vs. Forward Current**

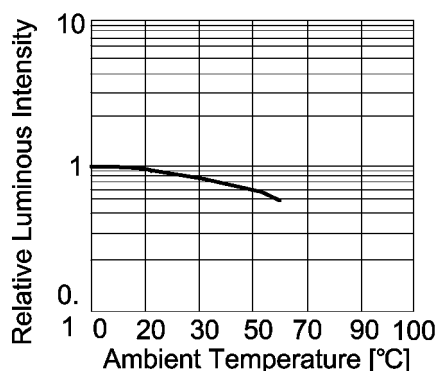

**Luminous Intensity  
Vs. Ambient Temperature**

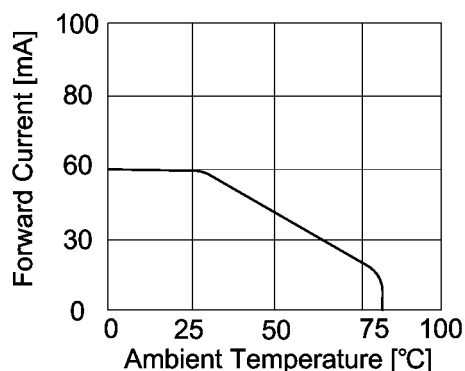

**Forward Current  
Vs. Ambient Temperature**

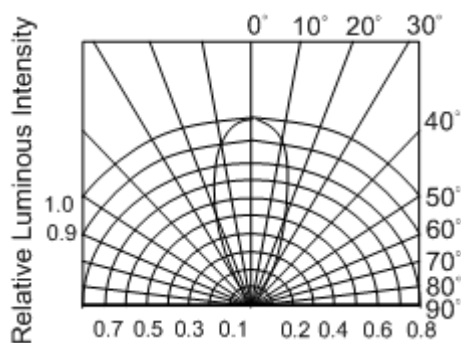

**Radiation Pattern**

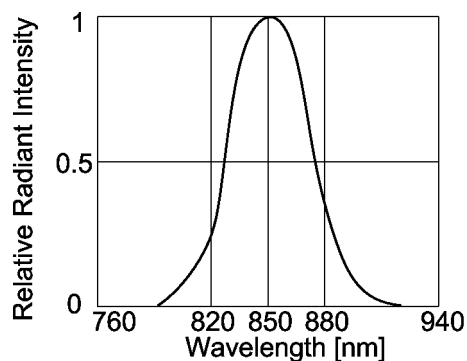

**Relative Luminous Intensity  
Vs. Wavelength**