





Drawing No.	*Rev.	Date	Page
BF5H25G-YUV-020mA	A	2018/08/17	1/3

APPROVAL SHEET

Part No: **BF5H25G-YUV-020mA**

NOTE : **Green Part**

MAKER			CUSTOMER	
				
R&D	QA	Sales	Checked	Approved
				

Prepared	Checked	Approved
Rachel Lee	Sky Lin	Kenneth Wu

DESCRIPTION:

Device Type : BF5H25G-YUV-020mA
 Dice Material : InGaN
 Light Color : UV
 Lens Color : Water Clear
 Lens Dimension : 5 mm

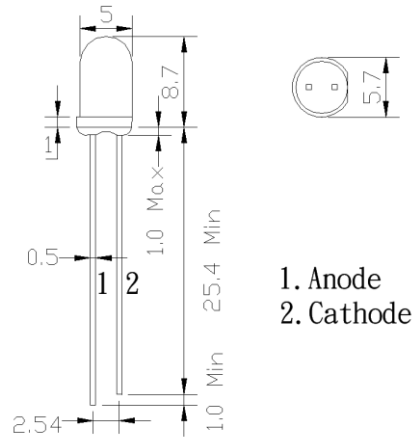

1. Anode
 2. Cathode

All epoxy resin dimension are in millimeter
 tolerance is $\pm 0.2\text{mm}$

Absolute Maximum Ratings at Ta=25°C

Parameter	Max.	Unit
DC Forward Current	30	mA
Reverse Voltage	5	V
Power Dissipation	120	mW
Operating Temperature	Topr : -30 ~ +80	°C
Storage Temperature	Tstr : -30 ~ +100	°C
Solder DIP (MAX. 5 seconds, 1.6mm from body) Temperature 260°C		

Electrical and Optical Characteristics at Ta=25°C

Symbol	Description	Test Condition	Min.	Typ.	Max.	Unit
V _F	Forward Voltage	I _F = 20mA	-	3.5	4.0	V
I _R	Reverse Current	V _R = 5V	-	-	10	μA
λ _P	Peak Emission Wavelength	I _F = 20mA	395	-	400	nm
Δλ	Spectral Line Halfwidth	I _F = 20mA	-	15	20	nm
2θ _{1/2}	Viewing Angle	I _F = 20mA	-	25	-	Deg.
P _o	Radiant Power	I _F = 20mA	20	-	50	mW

- Note:
1. The lead should be formed up to 5mm from the body of device without forming stress.
 2. Soldering shall be performed after lead forming.
 3. All dimensions are in millimeters
 4. Static Electricity and surge damage the LED lamps.

It is recommended to use a wrist band or anti-electrostatic glove when handing the LED lamp

LED LAMP Technical Data

Typical Optical-Electrical Characteristic Curves

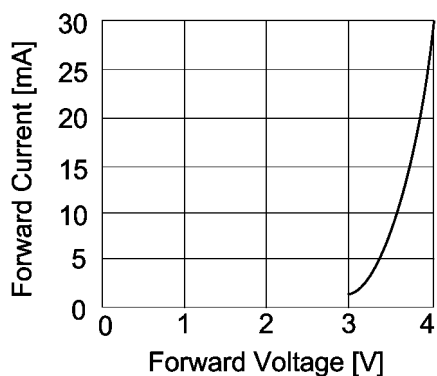

**Forward Current
Vs. Forward Voltage**

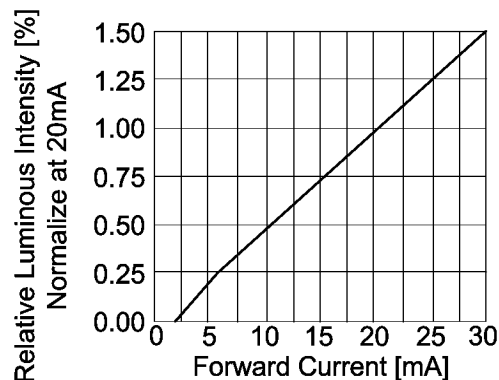

**Luminous Intensity
Vs. Forward Current**

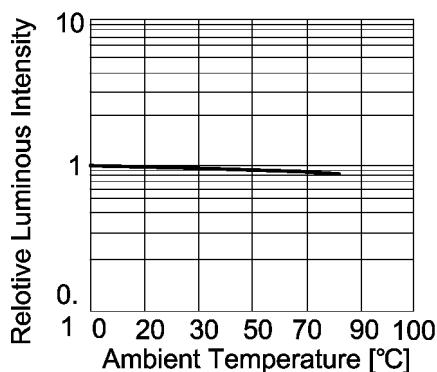

**Luminous Intensity
Vs. Ambient Temperature**

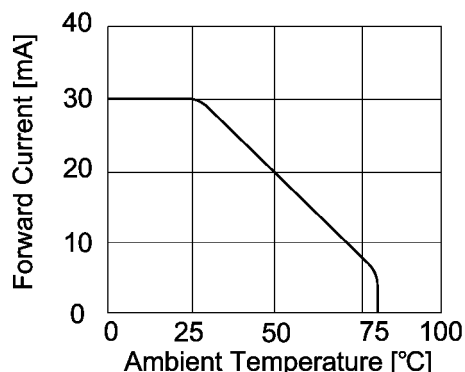

**Forward Current
Vs. Ambient Temperature**

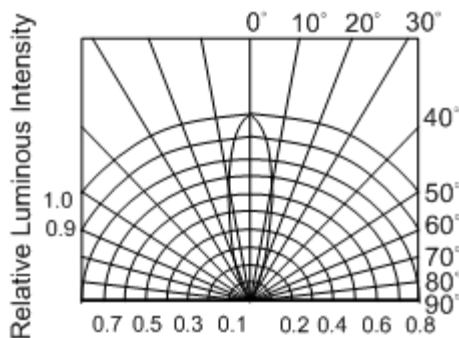

Radiation Pattern

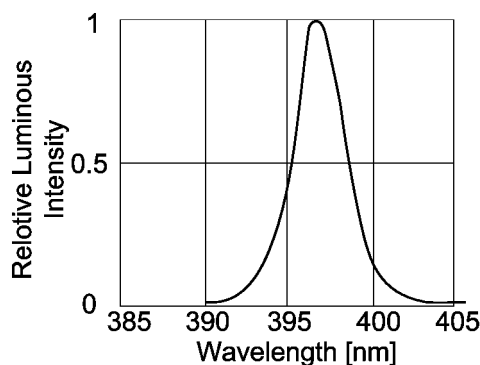

**Relative Luminous Intensity
Vs. Wavelength**