





Drawing No.	*Rev.	Date	Page
BF3H45G-BNH-020mA	A	2015/05/14	1/3

APPROVAL SHEET

Part No: **BF3H45G-BNH-020mA**

NOTE : Green Part

MAKER			CUSTOMER	
				
R&D	QA	Sales	Checked	Approved
				

Prepared	Checked	Approved
Rachel Lee	Sky Lin	Kenneth Wu

LED LAMP Technical Data

DESCRIPTION:

Device Type	: BF3H45G-BNH-020mA
Dice Material	: InGaN
Light Color	: Blue
Lens Color	: Blue Diffused
Lens Dimension	: 3 mm

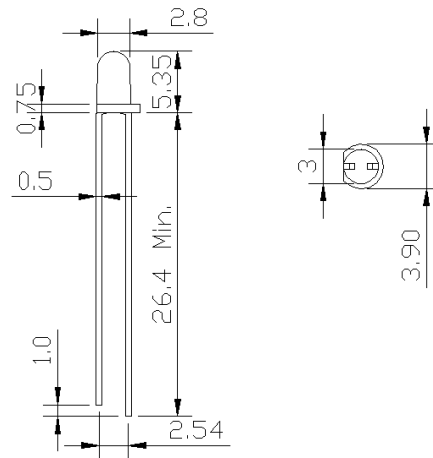

Absolute Maximum Ratings at Ta=25°C

Parameter	Max.	Unit
DC Forward Current	20	mA
Reverse Voltage	5	V
Power Dissipation	80	mW
Operating Temperature	Topr : -30 ~ +80	°C
Storage Temperature	Tstr : -30 ~ +100	°C
Solder DIP (MAX. 5 seconds, 1.6mm from body) Temperature 260°C		

Electrical and Optical Characteristics at Ta=25°C

Symbol	Description	Test Condition	Min.	Typ.	Max.	Unit
V _F	Forward Voltage	I _F = 20mA	-	3.5	4.0	V
I _R	Reverse Current	V _R = 5V	-	-	10	μA
λ _D	Dom. Emission Wavelength	I _F = 20mA	-	470	-	nm
Δλ	Spectral Line Halfwidth	I _F = 20mA	-	15	20	nm
2θ _{1/2}	Viewing Angle	I _F = 20mA	-	45	-	Deg.
I _v	Luminous Intensity	I _F = 20mA	150	-	400	mcd

- Note:
1. The lead should be formed up to 5mm from the body of device without forming stress.
 2. Soldering shall be performed after lead forming.
 3. All dimensions are in millimeters
 4. Static Electricity and surge damage the LED lamps.

It is recommended to use a wrist band or anti-electrostatic glove when handing the LED lamp

LED LAMP Technical Data

Typical Optical-Electrical Characteristic Curves

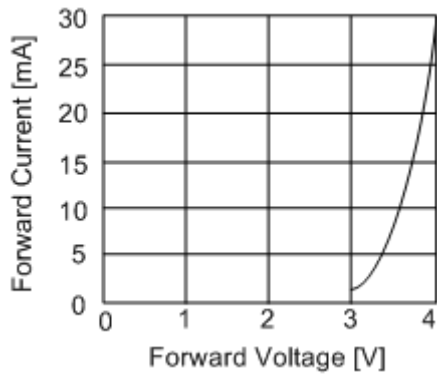

**Forward Current
Vs. Forward Voltage**

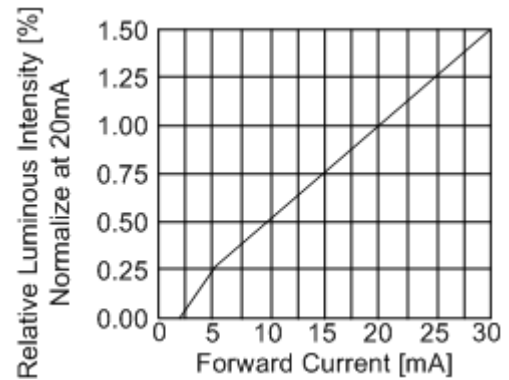

**Luminous Intensity
Vs. Forward Current**

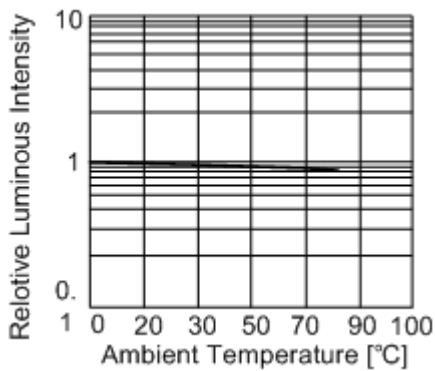

**Luminous Intensity
Vs. Ambient Temperature**

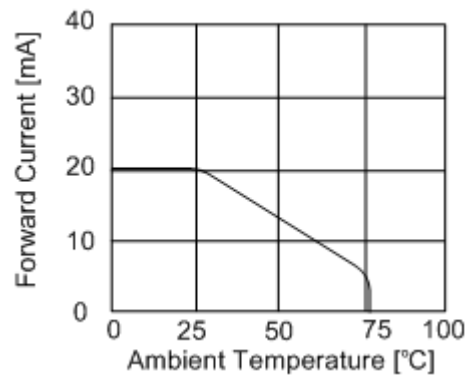

**Forward Current
Vs. Ambient Temperature**

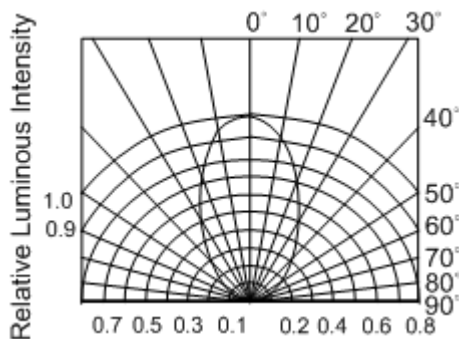

Radiation Pattern

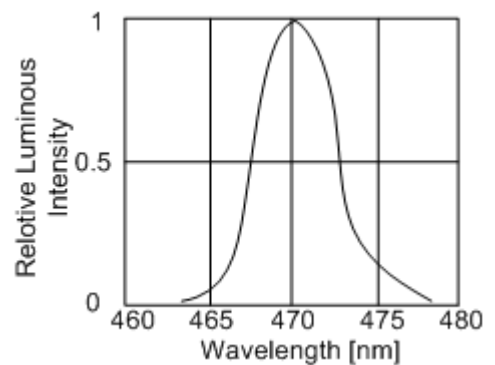

**Relative Luminous Intensity
Vs. Wavelength**