





Drawing No.	*Rev.	Date	Page
BB5050A-C3A	A	2022/08/22	1/12

APPROVAL SHEET

Part No: **BB5050A-C3A**

NOTE : Green Part

MAKER			CUSTOMER	
				
R&D	QA	Sales	Checked	Approved
				

Prepared	Checked	Approved
Rachel Lee	Sky Lin	Kenneth Wu

Drawing No.	*Rev.	Date	Page
BB5050A-C3A	A	2022/08/22	2/12

Features:

- 1.Meet RoHS.
- 2.Full Color SMD Chip LED With IC Control.
- 3.Top view Package in 12.0mm carrier tape on 7" diameter reel.
- 4.Each RGB chip is 8 bit control, total of 16M color can be displayed.

Descriptions:

The BB5050A-C3A SMD has wide viewing angle and optimized light coupling by inter reflector,The low current requirement makes this device ideal for portable equipment or any other application where power is at a premium

Applications

1. Consumer product, Home appliances, Telecommunication, light bar.
2. Toy lights, Christmas lights, Decorative lights.

Device Selection Guide:

PART NO	MATERIAL	COLOR	
		Emitted	Lens
BB5050A-C3A	AlGaInP	Red	Water Clear
	InGaN	Green	
	InGaN	Blue	

Package Dimensions

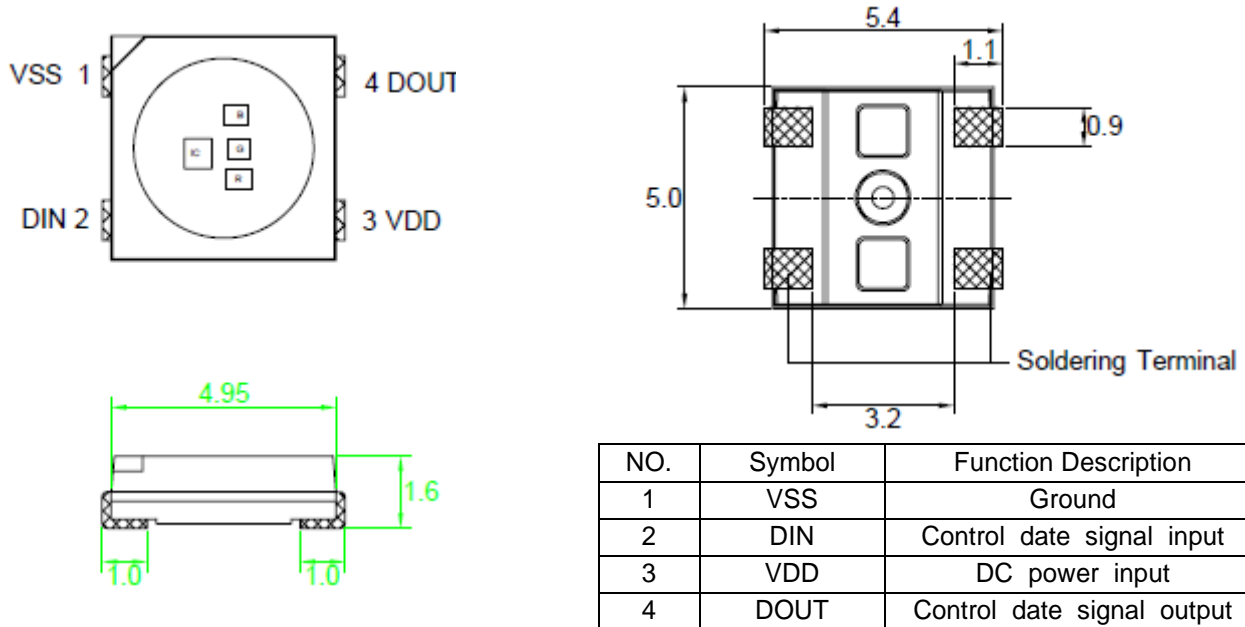

- Note : 1. All dimension are in millimeter tolerance is ± 0.1 mm unless otherwise noted.
 2. Specifications are subject to change without notice.

Recommended Soldering Pad Dimensions

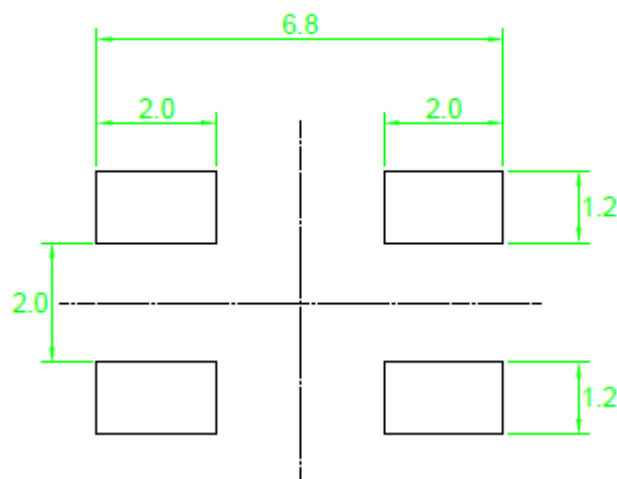

Note : The tolerances unless mentioned is ± 0.1 mm, Angle ± 0.5 . Unit=mm.

Absolute Maximum Ratings

(Ta=25°C, VDD=5V, VSS=0)

Parameter	Symbol	Ratings	UNIT
Supply Voltage	VDD	-0 ~ +6.0	V
LED Output Current	I _{OUT}	20	mA
Operating Temperature	T _{opr}	-40~ +85	°C
Storage Temperature	T _{stg}	-40 ~ +100	°C

Typical Electrical & Optical Characteristics

(Ta=25°C, VDD=5V, VSS=0)

Items	Symbol	Min.	Typ.	Max.	UNIT	CONDITION
Supply Voltage	VDD	3.3	5	5.5	V	-
Each R/G/B Current	IOL	-	12	-	mA	VDD=5V
Input High Voltage	VIH	2.7	-	VDD	V	DI,
Input Low Voltage	VIL	0	-	1.0	V	DI,
Output High Voltage	VOH	4.5	-	-	-	DO,@VDD=5V
Output Low Voltage	VOL	-	-	0.4 VDD	V	DO,@VDD=5V

Timing Wave Form

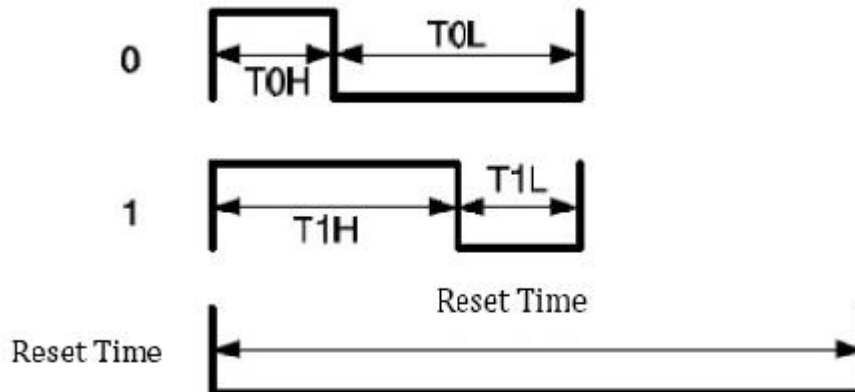

Item	Description	min	Typical	Allowance	unit
T0H	0 code, High-level time	-	0.3	±0.15	us
T0L	0 code, Low-level time	-	0.9	±0.15	us
T1H	1 code, High-level time	-	0.9	±0.15	us
T1L	1 code, Low-level time	-	0.3	±0.15	us
Trst	Reset code, Low-level time	250	-	-	us

Data Communication

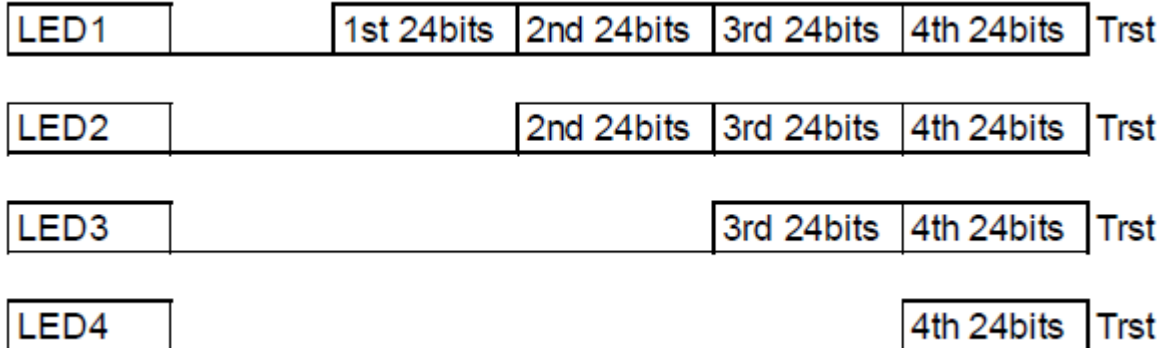

Single Data in 24bit for RGB

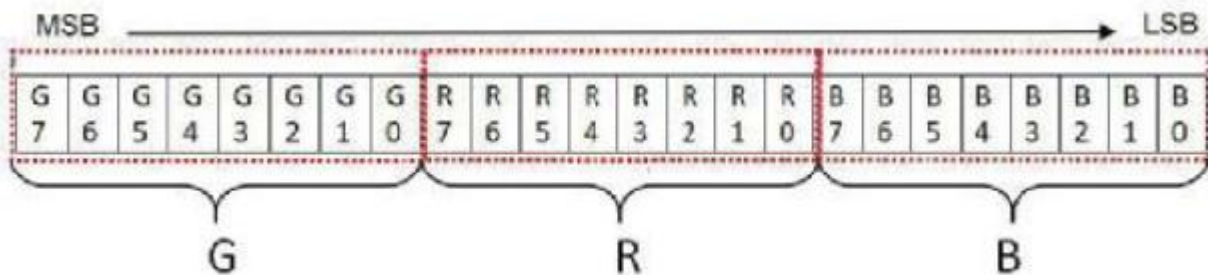

Control Commands for multiple strips connected parallely

BB5050A-C3A supports the scenarios of controlling multiple strips with parallel connection (up to 15 strips). With appropriate commands, each of the strips can be identified and assigned a unique strip dynamic ID (by set dynamic ID command). After the commands is completed, MCU host can individually control and send the display data to each strip with the help of "Clean ID" 、"Check ID" 、"specify ID" commands.

Electrical Optical Characteristics at Ta=25°C

Items	Symbol	Min.	Typ.	Max.	UNIT	CONDITION	
Luminous Intensity	Iv	R	200	425	1000	mcd	VDD = 5.0 V
		G	500	950	2000		
		B	125	210	500		
Dominant Wavelength	λD	R	615	622	630	nm	
		G	515	525	530		
		B	460	470	475		
Viewing Angle	2θ 1/2	120			deg		

- 1.The luminous intensity data did not including ±15% testing tolerance.
- 2.The dominant wavelength data did not including ±1nm testing tolerance.

Drawing No.	*Rev.	Date	Page
BB5050A-C3A	A	2022/08/22	8/12

Carrier Tape Dimensions

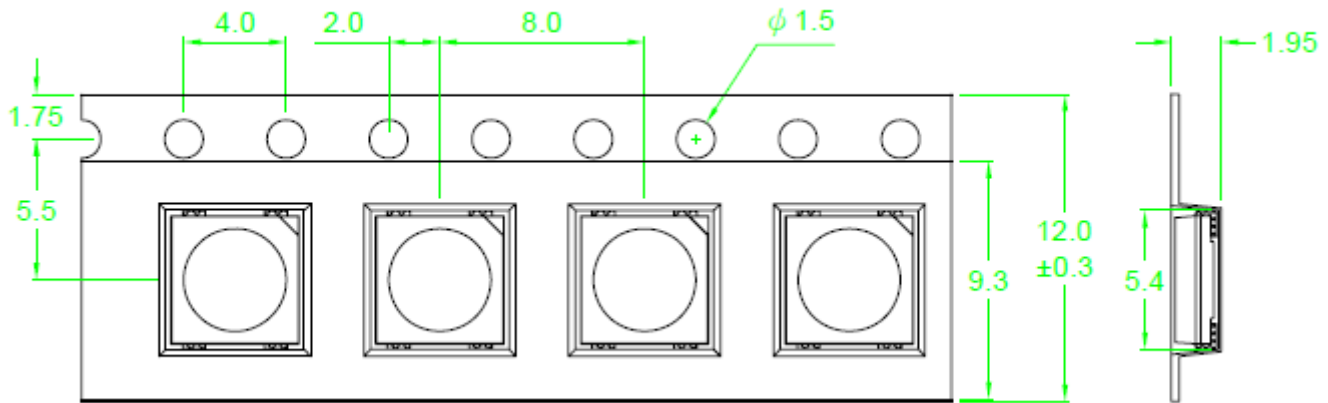

Note : The tolerances unless mentioned is $\pm 0.1\text{mm}$, Angle ± 0.5 . Unit=mm.

Packing Specifications

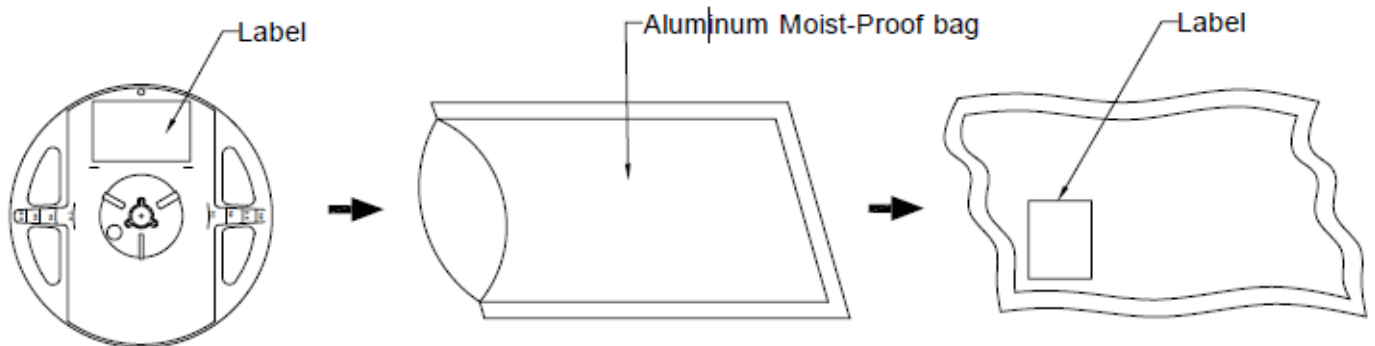

Part No.	Description	Quantity/Reel
BB5050A-C3A	12.0mm tape, 7" reel	1000 devices

Drawing No.	*Rev.	Date	Page
BB5050A-C3A	A	2022/08/22	9/12

Reel Dimensions

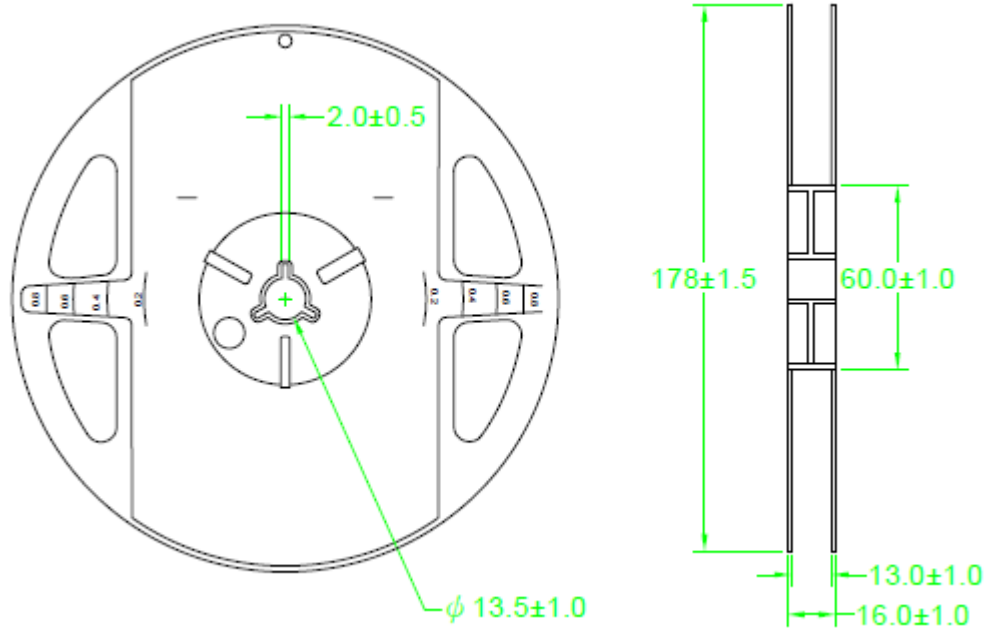

Drawing No.	*Rev.	Date	Page
BB5050A-C3A	A	2022/08/22	10/12

Box Explanation

1. 5 BAG / INNER BOX

2. INNER BOX SIZE : L X W X H 23cm X 8.5cm x 26cm

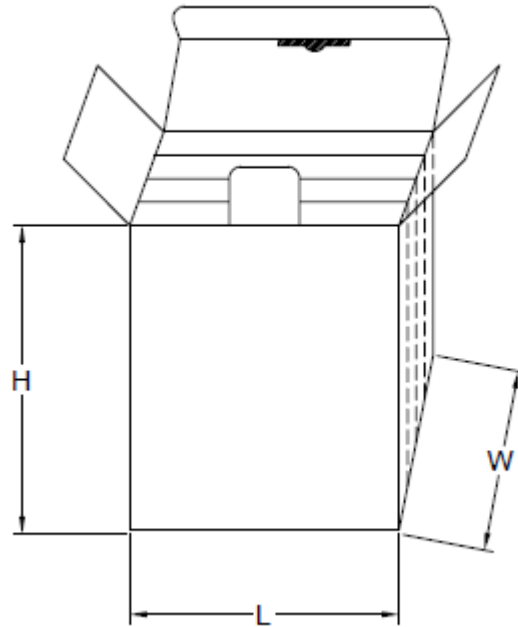

3. 10 INNER BOXES / CARTON

4. CARTON SIZE : L X W X H 58cm X 34cm x 35cm

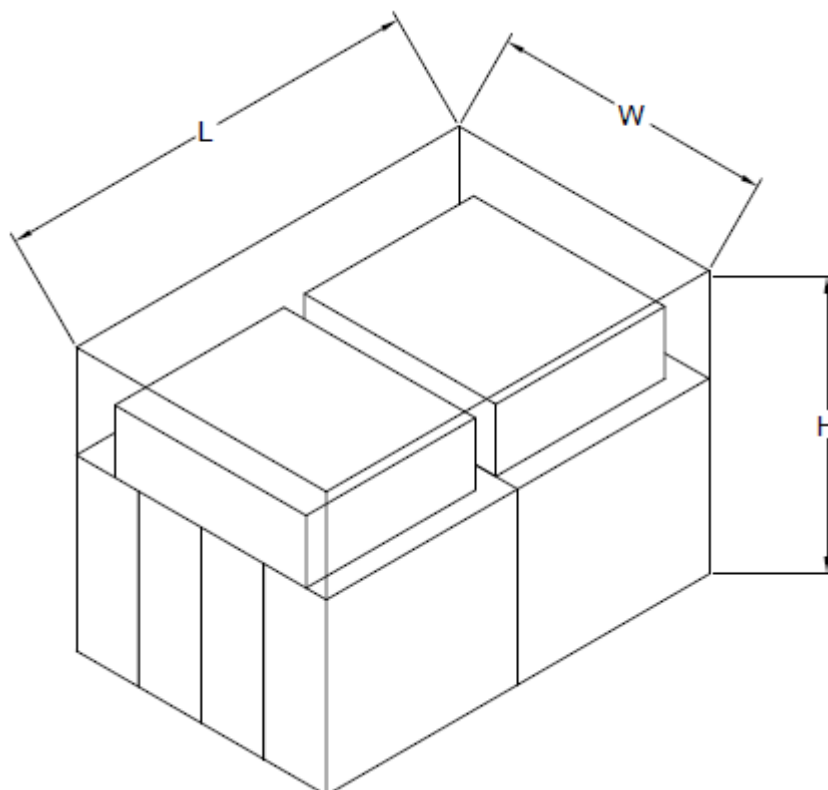

Recommended Soldering Conditions

1. Hand Solder

Basic spec is $\leq 280^{\circ}\text{C}$ 3 sec one time only.

2 PB-Free Reflow Solder

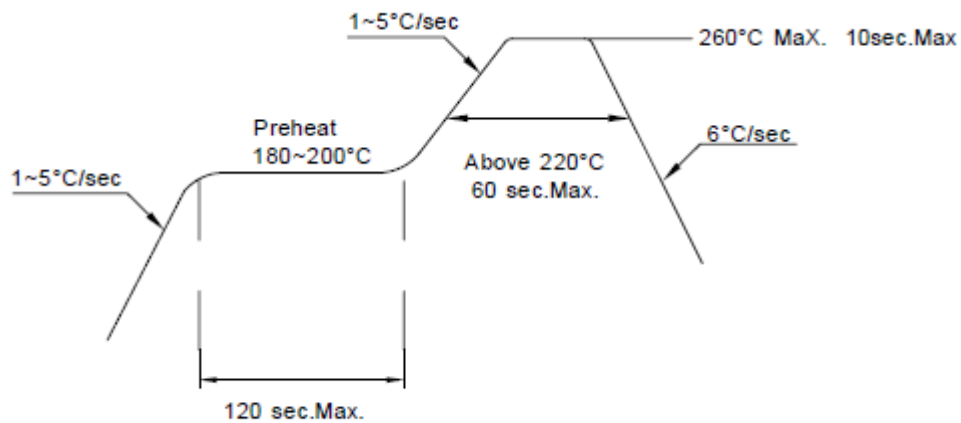

Note:

1. Reflow soldering should not be done more than two times.
2. When soldering, do not put stress on the LEDs during heating.
3. After soldering, do not warp the circuit board.

Precautions For Use:

Storage time:

1. Calculated shelf life before opening is 12 months at $< 30^{\circ}\text{C}$ and $< 90\%$ relative humidity (RH)
2. After bag is opened, devices which will be subjected to reflow soldering or other high temperature processes must be
 - a) Assembled within 24 hours in an environment of $\leq 30^{\circ}\text{C} / 60\%$ RH, or
 - b) Stored at ambient of 10% RH or less
3. Devices are required baking before assembly if:
 - a) Humidity Indicator Card reads $>10\%$ (for level 2a -5a) or $>60\%$ (for level 2) at ambient temperature $23\pm 5^{\circ}\text{C}$
 - b) 2.a) or 2.b) doesn't meet
4. If baking is required, devices should be baked for >24 hours at $60\pm 5^{\circ}\text{C} / 5\%$ RH. Performing baking only once, and using the baked devices within 8 hours.

Recommended route

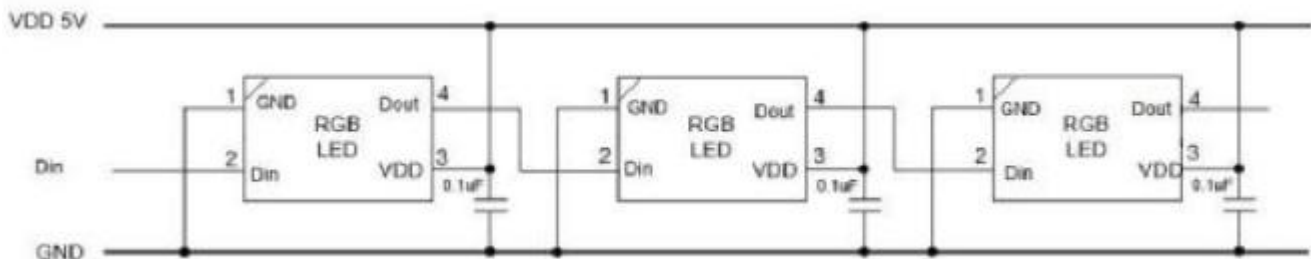

Cleaning:

Use alcohol-based cleaning solvents such as isopropyl alcohol to clean the LED.

ESD (Electrostatic Discharge):

Static Electricity or power surge will damage the LED. Use of a conductive wrist band or anti-electrostatic glove is recommended when handling these LED. All devices, equipment and machinery must be properly grounded.