





Drawing No.	*Rev.	Date	Page
BAR1010A-C3C-3P63mA	A	2025/02/26	1/16

APPROVAL SHEET

Part No: **BAR1010A-C3C-3P63mA**

NOTE : **Green Part**

MAKER			CUSTOMER	
				
R&D	QA	Sales	Checked	Approved
				

Prepared	Checked	Approved
Rachel Lee	Sky Lin	Kenneth Wu

Drawing No.	*Rev.	Date	Page
BAR1010A-C3C-3P63mA	A	2025/02/26	2/16

Description of P/N No.

BAR1010A – C3C – 3P63mA



SOLIDLITE LED – BAR1010A Series

RGB +IC Series

Test Condition

Description of Lot.

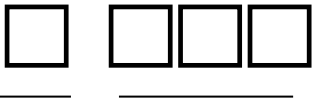

Month



NO.

Solidlite Corp.



P/N : _____

Lot : _____

Date: _____ . Rank: _____

Q'ty : _____ . QA : _____

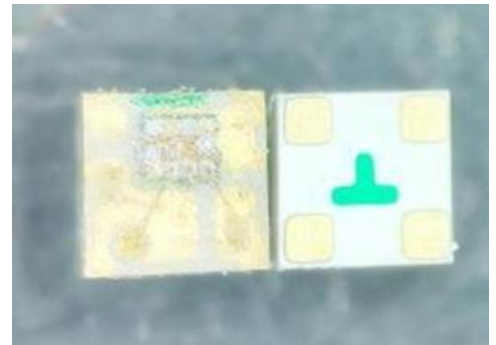

Intelligent external control LED

1.0x1.0x0.68mm

Small Size SMD LED

1. Description

BAR1010A-C3C-3P63mA is a special circuit for three-channel high-ash LED constant current drive, which integrates MCU single-line digital interface, data latch, LED constant current drive, PWM Luminance control, gamma correction and other circuits. It can be cascaded through dual-channel input and digital output interfaces, and its external controller can control the chip with only one line. The constant current value and PWM luminance value output by each OUT drive port can be independently set by command.

LED has the advantages of low voltage drive, environmental protection and energy saving, high brightness, large scattering angle, good consistency, ultra-low power, and ultra-long life. Integrating the control circuit on the LED makes the circuit simpler, smaller in size and easier to install.

2. Applications

- LED full-color luminous character string light, LED full-color module, LED symphony soft and Hard light bar, LED guardrail tube, LED appearance/scene lighting.
- LED point light source, LED pixel screen, LED special-shaped screen, various electronic products, electrical equipment marquee.

3. Features

- The default constant current output value is 3.63mA.
- With current gain function.
- The power-on does not light up by default.
- The constant current output value can be adjusted by the controller.
- Grayscale adjustment circuit (65536 grayscale adjustable);
- Built-in high precision and high stability oscillator
- With data shaping function: automatically shaping the subsequent data to output after receiving the data of this unit.
- Data transmission rate is 1.3 MHz
- Applicable fields: point light source, guard rail tube, glass screen, flexible transparent screen, etc.
- Package form: light drive integrated package.

4. Package Dimensions

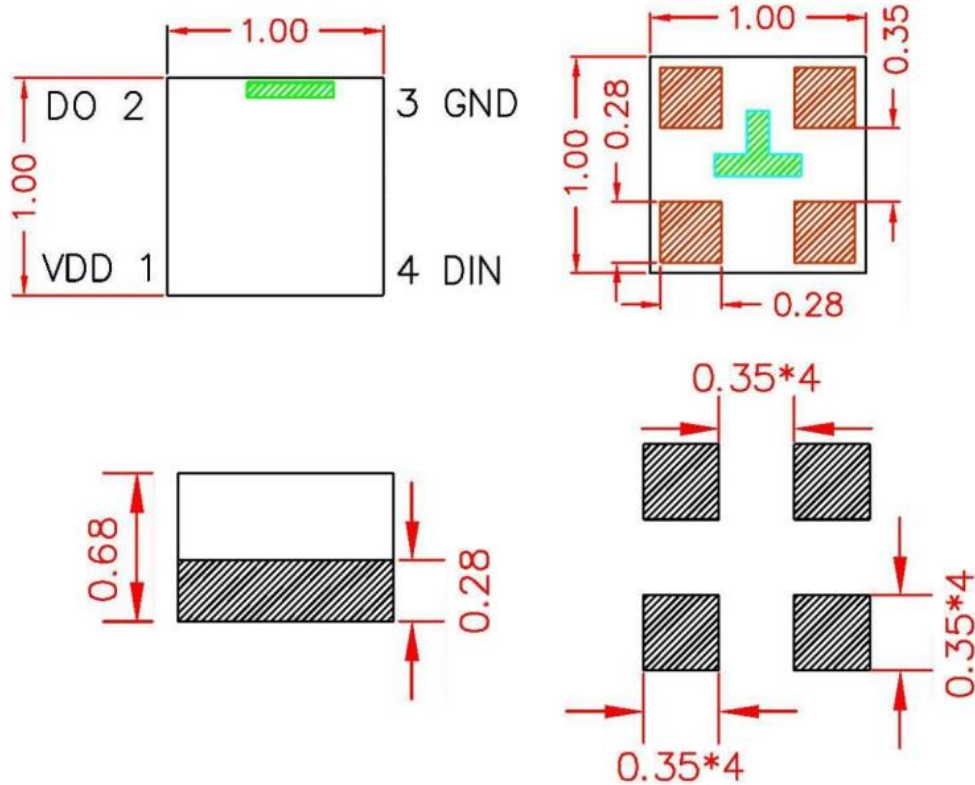

Recommended size of solder pad

Note:

- All dimensions are in mm.
- Unless otherwise specified, the tolerance of all marked dimensions is ± 0.05 mm
- Package size : 1.0x1.0x0.68mm

5. Pin function

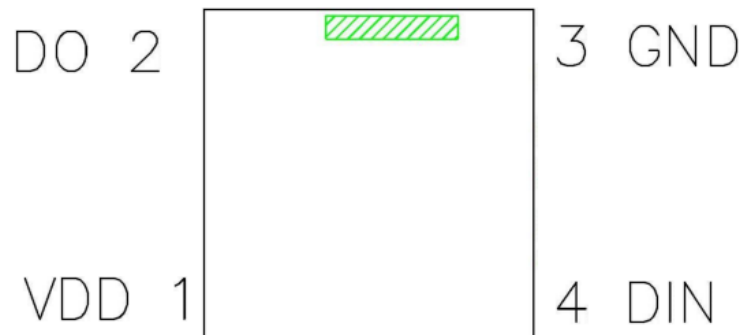

Pin No	Symbol	Pin name	Function description
1	VDD	Power supply	Power supply pins
2	DO	Data output	Control data signal output
3	GND	Ground	Signal ground and power ground
4	DIN	Data input	Control data signal input

6. Electro-optical characteristics at Ta=25°C (RGB)

Item	Symbol	Mix	Typ	Max	Unit	Conditions	
Dominant wavelength	λ_d	G	520	-	525	nm	IF=3.63mA
		R	620	-	625		
		B	465	-	470		
Luminous intensity	IV	G	200	-	400	mcd	IF=3.63mA
		R	50	-	100		
		B	30	-	80		

7. Absolute maximum ratings at Ta=25°C

Parameter	Symbol	Min	Typical	Max	Unit	Test conditions
Logic supply voltage	VDD	3.0	-	5.5	V	-
R/G/B output port With stand voltage	Vds	-	9	-	V	-
Logic input voltage	VI	-0.5	-	5.5	V	-
Operating temperature Range	Ta	-40	-	85	°C	-
Operating junction temperature range	Tj	-40	-	85	°C	-
Electrostatic ESD	HBM	-	-	3000	V	Human Body Mode

8. IC Electric Spec

Parameter name	Symbol	Test conditions	Min	Typical	Max	Unit
Input Voltage	V _{DD}	--	4	5	5.5	V
R/G/B output drive current	I _O	V _{ds} =1V	--	3.63	12	mA
High level input voltage	V _{IH}	V _{DD} =5V	0.7V _{DD}	--	--	V
Low level input voltage	V _{IL}	V _{DD} =5V	--	--	0.3V _{DD}	V
DO pull current capability	I _{oh}	V _{DD} =5V, V _{ds} =1V	--	16	--	mA
DO fill current capability	I _{ol}	V _{DD} =5V, V _{ds} =4V	--	26	--	mA
Static current	I _{dd}	V _{DD} =4.0V	--	0.8	--	mA
OUT output current	I _{out}	R, G, B=ON, V _{out} =3.0V	0.71	--	12	mA
OUT output leakage current	I _{olk}	R, G,B=OFF, V _{out} =5.0V	--	--	0.3	uA
Inter-channel constant Current error	△I _{olc0}	R,G,B=ON, V _{out} =3.0V	--	--	±3	%
Inter IC constant Current error	△I _{olc1}	R,G,B=ON, V _{out} =3.0V	--	--	±5	%

9. Dynamic parameter

Parameter name	Symbol	Test conditions	Min	Typical	Max	Unit
Data transfer rate	F_{DIN}	VDD=5V	1	1.3	--	MHz
PWM frequency	F_{PWM}	--	--	4	--	KHz
Transmission delay time	T_{PLZ}	DIN→DO	--	--	200	ns
Output current Conversion time	T_r	Vds=1.5V I _O =3.63mA	--	--	60	ns
	T_f		--	--	60	ns

10. The data transmission time

Parameter name	Symbol	Test conditions	Min	Typical	Max	Unit
0 code, high level time	T0H	VDD=5.0V	200	240	280	ns
1 code, high level time	T1H	VDD=5.0V	400	480	560	ns
0 code, low level time	T0L	VDD=5.0V	400	480	560	ns
1 code, low level time	T1L	VDD=5.0V	200	240	280	ns
Reset code, low level time	Trst	--	80	--	--	us

11. Functional

BAR1010A-C3C-3P63mA adopts single-line communication mode and it sends signals by way of return-to-zero code. BAR1010A-C3C-3P63mA When the reception reaches 48 bits, the DO port starts to forward data to provide input data for the next BAR1010A-C3C-3P63mA. Before forwarding, the DO port is always pulled low. At this time, BAR1010A-C3C-3P63mA will not receive new data, and the three PWM output ports of the chip (OUTR, OUTG, and OUTB) send out corresponding signals with a frequency of 4 kHz, with different duty ratios according to the received 48-bit data.

If the input signal at the DIN terminal is a RESET signal, BAR1010A-C3C-3 P63mA will receive new data again after the end of this signal. After receiving the initial 48-bit data, BAR1010A-C3C-3P63mA will forward the data through the DO port. Before receiving the RESET code, the original outputs of the OUTR, OUTG, and OUTB pins will remain unchanged.

After receiving the low-level RESET code for more than 80 μ s seconds, BAR1010A-C3C-3P63mA will output the pulse width of the 48-bit PWM data just received to OUTF, OUTB, and BAR1010A-C3C-3P63mA.

BAR1010A-C3C-3P63mA adopts automatic shaping and forwarding technology, so the number of cascades of BAR1010A-C3C-3P63mA is not limited by signal transmission, but only by the requirement of screen brushing speed.

12. Mode of data transmission

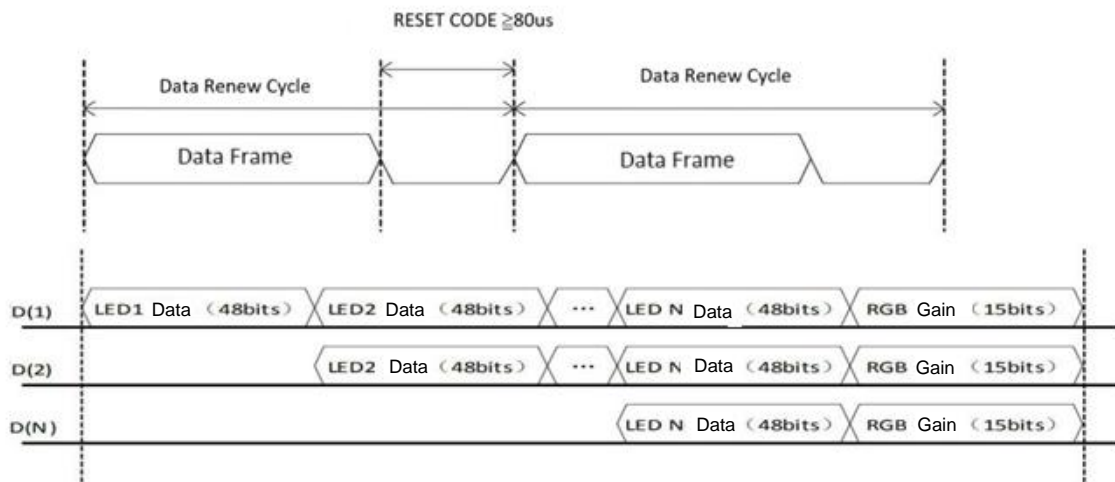

Note: Data frame D(1) is the data sent by MCU .D(2) and D(N) are the data automatically shaped And forwarded by the cascade circuit.

13. Data structure

- 48 bits data structure of LED brightness, the high bit is sent first, and the data is sent in RGB order.

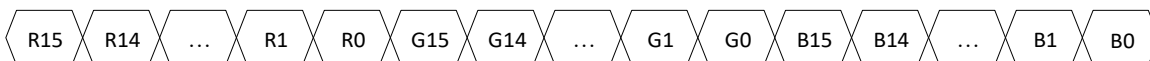

- 15bits data structure of RGB gain, high bits are sent first, and data is sent in RGB order.

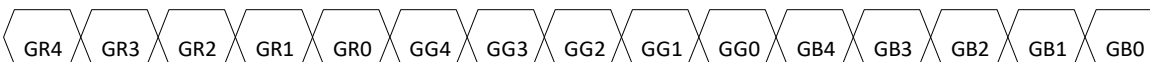

Drawing No.	*Rev.	Date	Page
BAR1010A-C3C-3P63mA	A	2025/02/26	9/16

14. Typical application circuit

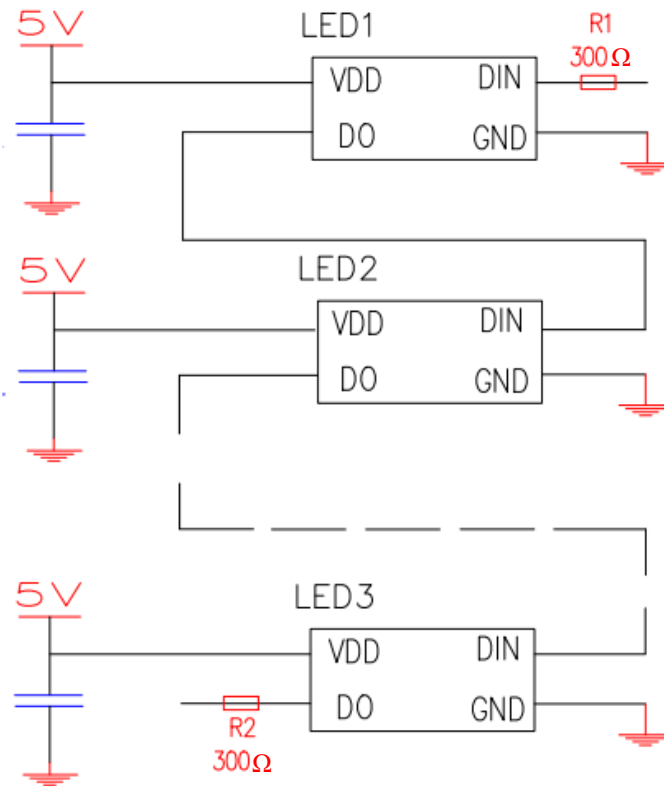

15. Current gain The default gain setting is 8 , and the current value is 3.63mA

RGB gain setting	RGB output (mA)
0	0.71
1	1.07
2	1.46
3	1.81
4	2.18
5	2.55
6	2.94
7	3.30
8	3.63
9	3.98
A	4.36
B	4.74
C	5.11
D	5.48
E	5.87
F	6.24
10	6.47
11	6.83
12	7.22
13	7.60
14	7.96
15	8.34
16	8.73
17	9.08
18	9.40
19	9.77
1A	10.15
1B	10.54
1C	10.90
1D	11.27
1E	11.67
1F	12.00

16. Typical optical characteristics curves

■ Color Spectrogram

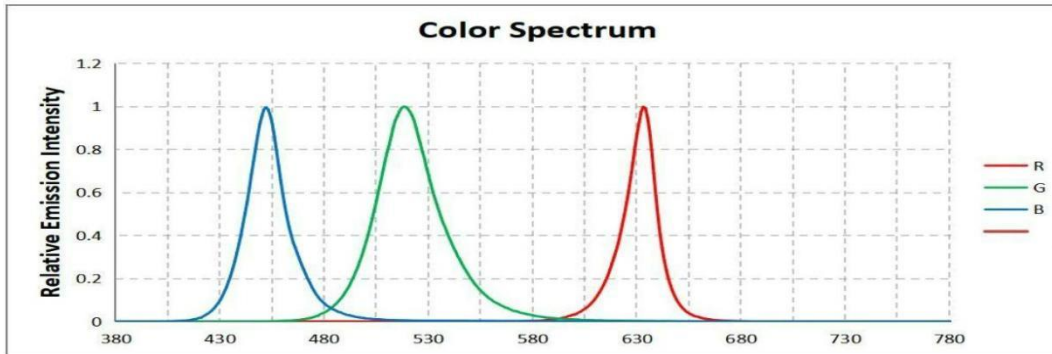

■ Forward Voltage VS. Forward Current, $T_a=25^\circ\text{C}$

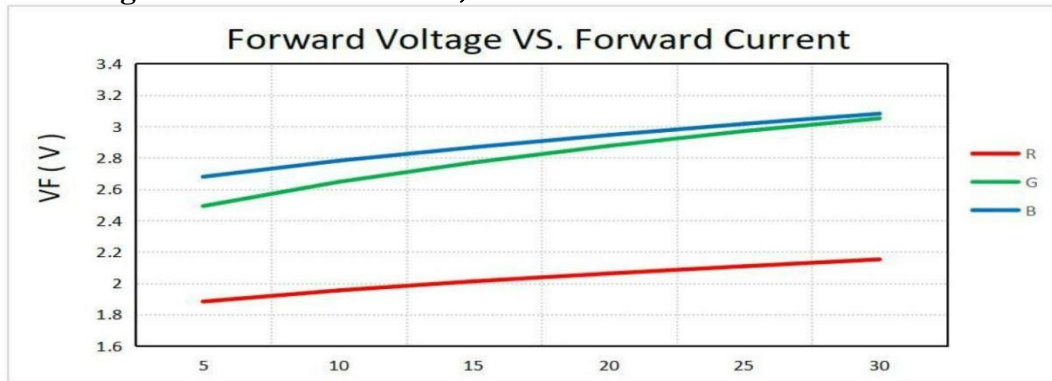

■ Relative Luminous Flux vs. Forward Current, $T_a=25^\circ\text{C}$

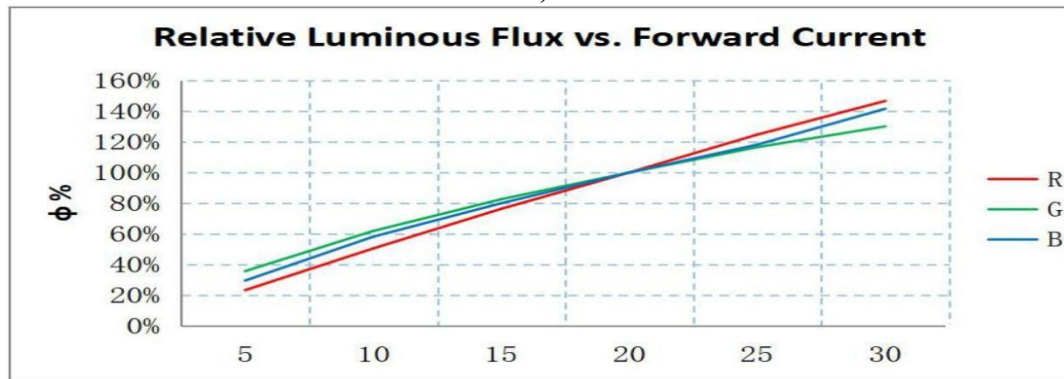

■ Radiation diagram, $T_a=25^\circ\text{C}$, $I_f=12\text{mA}$

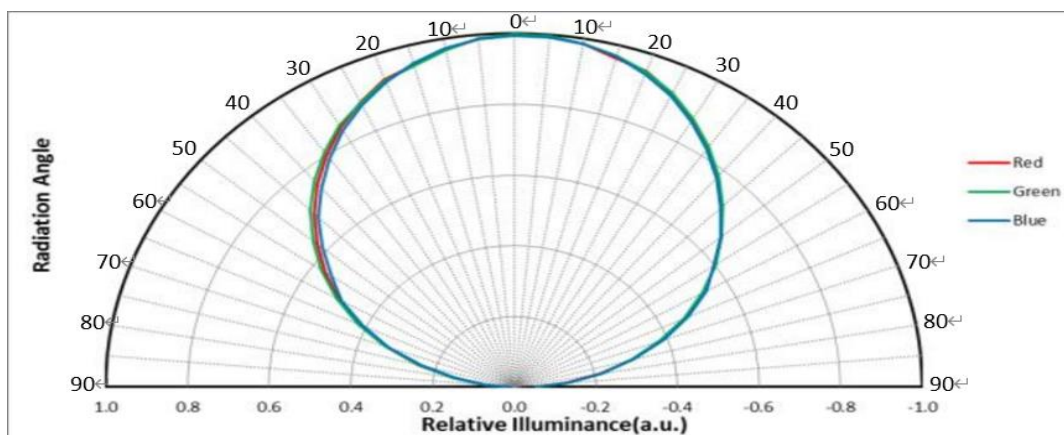

17. Packaging Specifications

● Feeding Direction

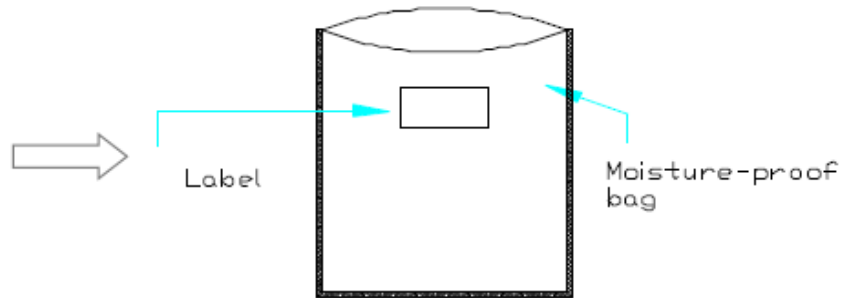
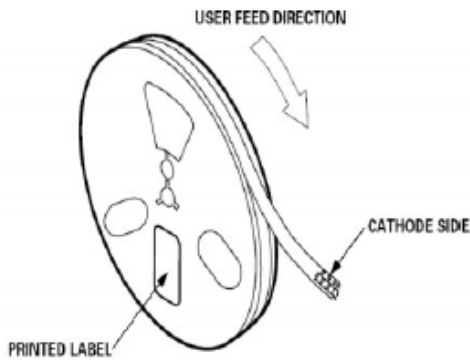
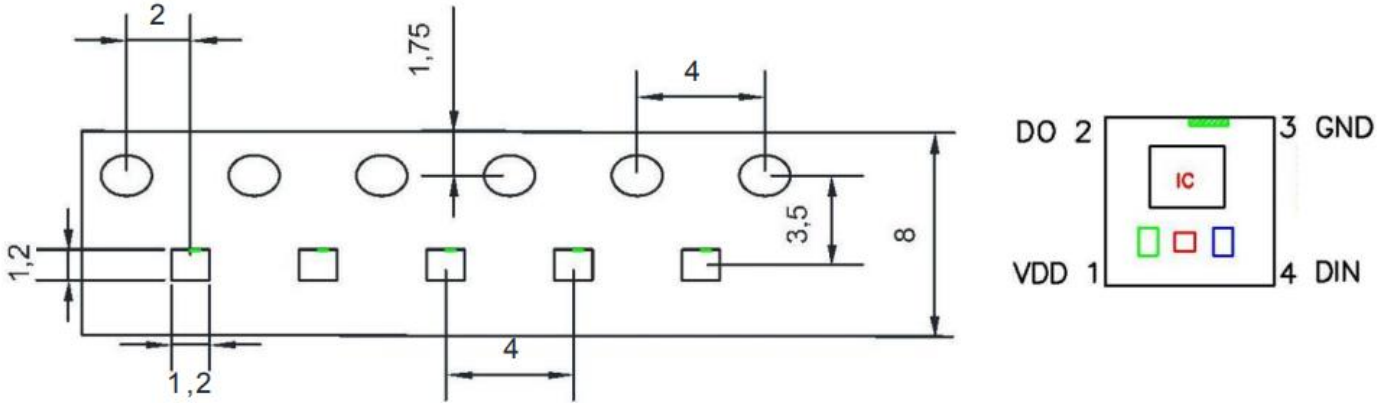

Vacuum

Solidlite Corp.	
P/N : _____	
Lot : _____	
Date: _____, Rank: _____	
Qty : _____, QA : _____	

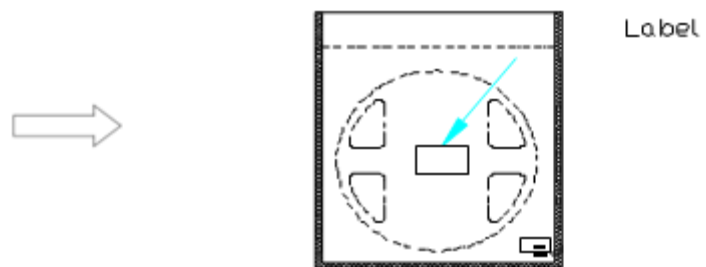

● Feeding Direction

Reel size: 178x12mm, 5000pcs/reel

Reel size: 330x12mm, 20000pcs/reel

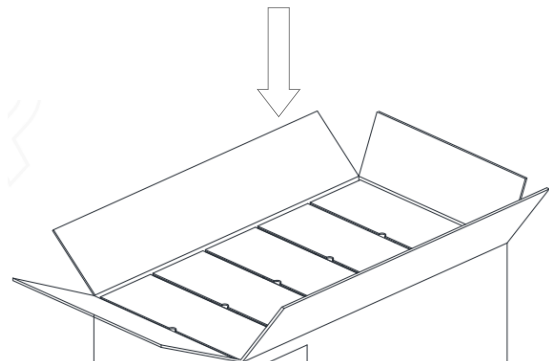

18. Reliability

TEST ITEMS AND RESULTS

Item	Test Item	Ref. Standard	Test Conditions	Note	Conclusion
1	Reflow Soldering	JESD22-B106	Tsld=240°C,10sec	3times	0/22
2	Temperature Cycle	JESD22-A104	-20°C30min ↑↓ 15min 120°C30min	200cycle	0/22
3	Thermal Shock	JESD22-A106	-40°C15min ↑↓ 15sec 125°C15min	200cycle	0/22
4	High Temperature Storage	JESD22-A103	T _a =100°C	1000hrs	0/22
5	Low Temperature Storage	JESD22-A119	T _a =-40°C	1000hrs	0/22
6	Power temperature Cycling	JESD22-A105	On5min-40°C>15min ↑↓ <15min ↑↓ Off5min100°C>15min	200cycle	0/22
7	Life Test	JESD22-A108	T _a =25°C I _F =12mA	1000hrs	0/22
8	High Humidity Heat Life Test	JESD22-A101	60°CRH=90% I _F =12mA	1000hrs	0/22

19. Reflow profile

SMD Reflow Soldering Instructions

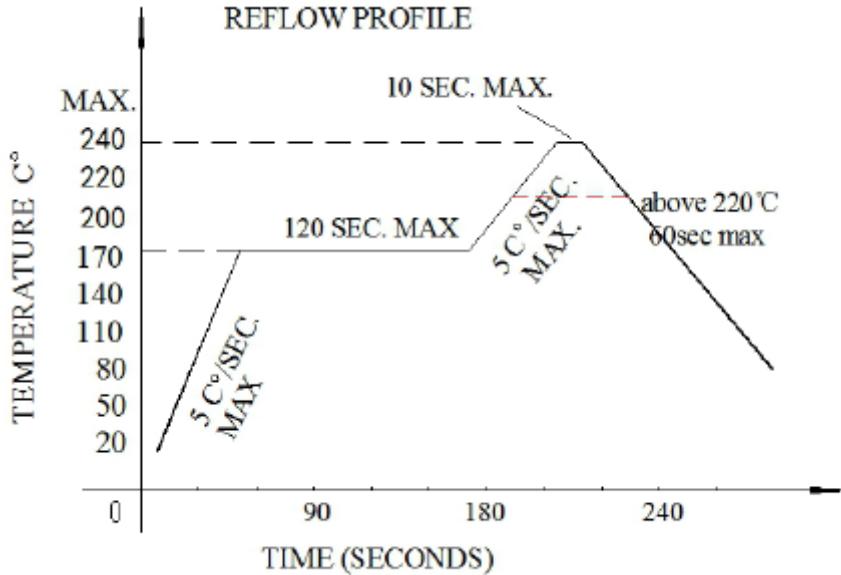

- Reflow soldering should not be done more than two times.
- When soldering, do not put stress on the LEDs during heating.

Soldering iron

- When hand soldering, keep the temperature under 300°C, and at that temperature keep the time under 3 sec.
- The hand soldering should be done only by once.

Rework

- The rework should be done withing 5 seconds at the temperature that is below 240°C.
- The head of iron cannot touch the LEDs
- Twin-head type is preferred.

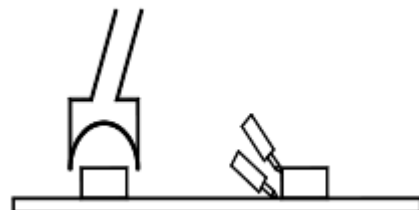

Drawing No.	*Rev.	Date	Page
BAR1010A-C3C-3P63mA	A	2025/02/26	15/16

20. CAUTIONS

In order to ensure that IC lamp beads are used in SMT patch reflow welding and in the use of the process yield and stability of the product, the following procedures are specified after many tests:

- a. Sample evaluation: Because this product is a built-in IC product, the overall process is different from conventional RGB products, so the customer side needs to carry out all-round verification during the sample evaluation to ensure the matching performance of the product
- b. Incoming material inspection: Ensure the vacuum packing is intact and there is no vacuum leakage. If there is vacuum leakage, please confirm whether the reflow welding is abnormal. If it is abnormal, please return to the factory for high-temperature dehumidification.
- c. Use: Please confirm the first piece before the formal SMT. According to the principle of one pack and one package, the lamp bead should not be exposed to air for more than 4 hours. The lamp bead should be reflow welded within 2 hours after the SMT is finished.
- d. Maintenance: Material should be completed within 4 hours and domestic demand after reflow soldering test and repair. For the lamp bead, if more than 4 hours have passed, the lamp plate temperature needs to be raised above 65°C for dehumidification for 12 hours before repair work. The lamp bead must also undergo low-temperature dehumidification above 65°C for 12 hours.
- e. Warm prompt: The whole process requires special considerations for light beads before use, including vacuum packing, dehumidification, SMT placement time, and workshop temperature and humidity control.
If the product maintenance lamp plate is exposed to a room temperature environment for a long time, dehumidification is required. For light boards and light beads, as LED electronic products, attention should be paid to moisture control in spring and summer, and anti-static measures in autumn and winter. Product quality is the lifeline of an enterprise. Striving for survival through quality and achieving development through quality is our consistent aim.
Also, in order to ensure the quality of the client's product, please strictly refer to the above recommendations.

Definition of moisture resistance

Moisture resistance level verification						
Moisture resistance level	Life span after unpacking		Verification condition			
	Time	Condition	Standard conditions		Accelerated conditions	
			Time	Condition	Time	Condition
LEVEL1	Unlimited	$\cong 30^{\circ}\text{C}/85\%\text{RH}$	168+5/-0H	85 $^{\circ}\text{C}/85\%\text{RH}$	/	/
LEVEL2	1year	$\cong 30^{\circ}\text{C}/60\%\text{RH}$	168+5/-0H	85 $^{\circ}\text{C}/60\%\text{RH}$	/	/
LEVEL2 a	4weeks	$\cong 30^{\circ}\text{C}/60\%\text{RH}$	696+5/-0H	30 $^{\circ}\text{C}/60\%\text{RH}$	120+5/-0H	60 $^{\circ}\text{C}/60\%\text{RH}$
LEVEL3	168hours	$\cong 30^{\circ}\text{C}/60\%\text{RH}$	192+5/-0H	30 $^{\circ}\text{C}/60\%\text{RH}$	40+5/-0H	60 $^{\circ}\text{C}/60\%\text{RH}$
LEVEL4	72hours	$\cong 30^{\circ}\text{C}/60\%\text{RH}$	96+5/-0H	30 $^{\circ}\text{C}/60\%\text{RH}$	20+5/-0H	60 $^{\circ}\text{C}/60\%\text{RH}$
LEVEL5	48hours	$\cong 30^{\circ}\text{C}/60\%\text{RH}$	72+5/-0H	30 $^{\circ}\text{C}/60\%\text{RH}$	15+5/-0H	60 $^{\circ}\text{C}/60\%\text{RH}$
LEVEL5 a	24hours	$\cong 30^{\circ}\text{C}/60\%\text{RH}$	48+5/-0H	30 $^{\circ}\text{C}/60\%\text{RH}$	10+5/-0H	60 $^{\circ}\text{C}/60\%\text{RH}$
LEVEL6	Take out And use	$\cong 30^{\circ}\text{C}/60\%\text{RH}$	Take out and use	30 $^{\circ}\text{C}/60\%\text{RH}$	/	/

