





Drawing No.	*Rev.	Date	Page
BA0402A-ZON-020mA	B	2020/07/09	1/11

APPROVAL SHEET

Part No: BA0402A-ZON-020mA

NOTE : Green Part

MAKER			CUSTOMER	
				
R&D	QA	Sales	Checked	Approved
				

Prepared	Checked	Approved
Rachel Lee	Sky Lin	Kenneth Wu

Drawing No.	*Rev.	Date	Page
BA0402A-ZON-020mA	B	2020/07/09	2/11

Description of P/N No.

BA0402A – ZON – 020mA



SOLIDLITE LED –BA0402A Series



Orange Series



Test Condition

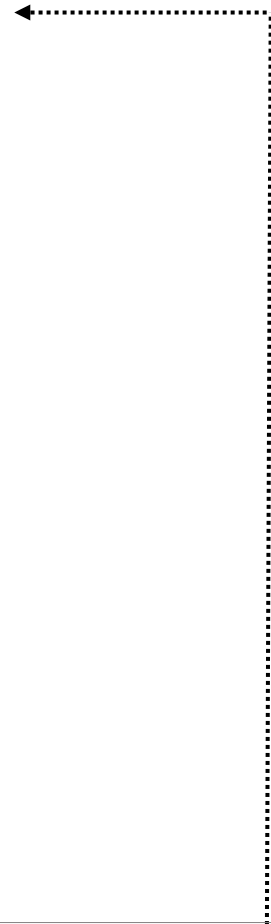

Description of Rank

See the page.4/11



Solidlite Corp.		
P/N :	<input type="text"/>	.
Lot :	<input type="text"/>	.
Date:	<input type="text"/>	Rank: <input type="text"/>
Q'ty :	<input type="text"/>	QA : <input type="text"/>

Product Specifications

Item	Specification	Material	Quantity
Luminous Intensity(Iv)	ZON:28.5-112.5 mcd @20mA/ Ts= 25°C ;Tolerance: $\pm 10\%$	—	—
Wavelength	ZON:600.0-612.0 nm @20mA/ Ts= 25°C ;Tolerance: $\pm 0.5\text{nm}$	—	—
Vf	ZON:1.6-2.4V @20mA/ Ts= 25°C ;Tolerance: $\pm 0.05\text{V}$	—	—
Ir	< 10 μA @ Vr = 5 V	—	—
Resin	Diffused	Epoxy	—
Carrier tape	EIA 481-1A specs	Conductive black tape	—
Reel	EIA 481-1A specs	Conductive black	—
Label	Solidlite standard	Paper	—
Packing bag	220x240mm	Aluminum laminated bag/ no-zipper	One reel per bag
Carton	Solidlite standard	Paper	Non-specified

Others:

Each immediate box consists of 5 reels. The 5 reels may not necessarily have the same lot number or the same bin combinations of Iv, λ_D and Vf. Each reel has a label identifying its specification; the immediate box consists of a product label as well.

Note :This is shipped test conditions

※Remarks: This product should be operated in forward bias. If a reverse voltage is continuously applied to the product, such operation can cause migration resulting in LED damage.

ATTENTION: Electrostatic Discharge (ESD) protection



The symbol to the left denotes that ESD precaution is needed. ESD protection for GaP and AlGaAs based chips is necessary even though they are relatively safe in the presence of low static-electric discharge. Parts built with AlInGaP, GaN, or/and InGaN based chips are **STATIC SENSITIVE devices**. ESD precaution must be taken during design and assembly.

If manual work or processing is needed, please ensure the device is adequately protected from ESD during the process.



Drawing No.	*Rev.	Date	Page
BA0402A-ZON-020mA	B	2020/07/09	4/11

Specifications Range

■ Luminous Intensity (Iv) Bin:

Color	Bin Code	Spec. Range
ZON	N	28.50-45.00 mcd
	P	45.00-71.50 mcd
	Q	71.50-112.5 mcd

Note: It maintains a tolerance of $\pm 10\%$ on Luminous Intensity

■ Wavelength Bin:

Color	Bin Code	Spec. Range
ZON	B	600.0-603.0 nm
	C	603.0-606.0 nm
	D	606.0-609.0 nm
	E	609.0-612.0 nm

Note: It maintains a tolerance of $\pm 0.5\text{nm}$ on Wavelength Bin

■ Forward Voltage (Vf) Bin:

Color	Bin Code	Spec. Range
ZON	E18	1.6-2.4 V

Note: It maintains a tolerance of $\pm 0.05\text{V}$ on forward voltage measurements

Product Features

Electro-Optical Characteristics

(T_{Soldering}, 25 °C)

Series	Emitting Color	Material	V _F (V)		Wavelength λ(nm)			I _v (mcd)	Viewing Angle $2\theta_{\frac{1}{2}}$
			typ	max	λ _D	λ _P	Δλ	Typical	
BA0402A-ZON-020mA	ZON	AllnGaP	2.0	2.4	605	611	17	71.5	X=120 Y=128

Package Outline Dimension and Recommended Soldering Pattern for Reflow Soldering

(Unit:mm Tolerance: +/-0.1)

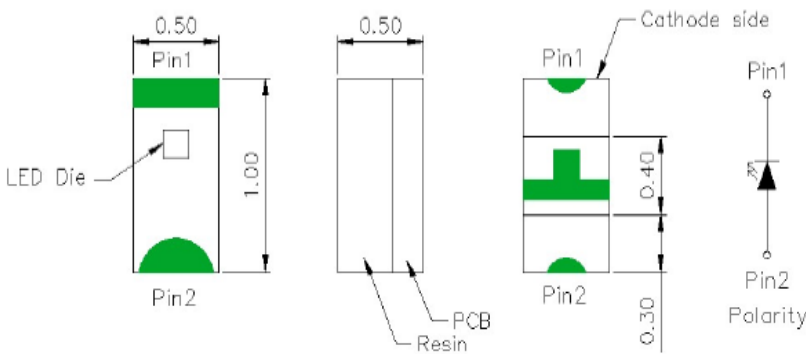
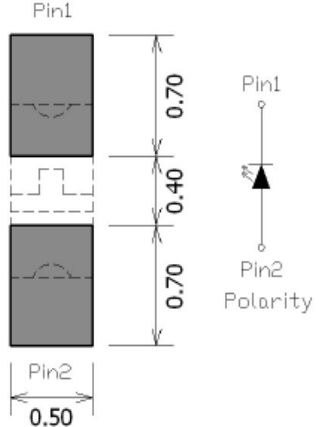
Outline Dim.	Soldering Pattern
	

Soldering terminals may shift in the x, y direction.

Absolute Maximum Ratings

(T_{Soldering} 25 °C)

Series	P _D (mW)	I _F (mA)	I _{FP} (mA)*	T _{OP} (°C)	T _{ST} (°C)
Color	Power Dissipation	Forward Current	Pulse Forward Current	Operating Temperature	Storage Temperature
ZON	48	20	40	-40~+85	-40~+100

*Condition for IFP is pulse of 1/10 duty and 0.1msec width

Drawing No.	*Rev.	Date	Page
BA0402A-ZON-020mA	B	2020/07/09	6/11

Characteristics of BA0402A-ZON-020mA

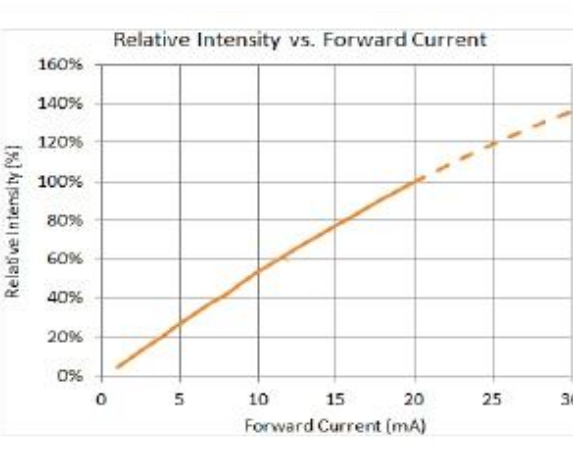
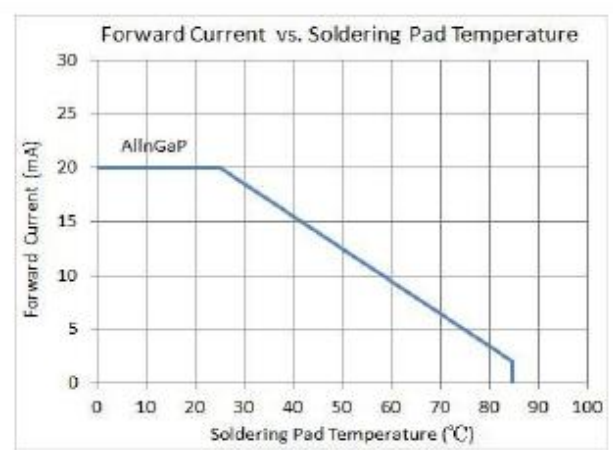
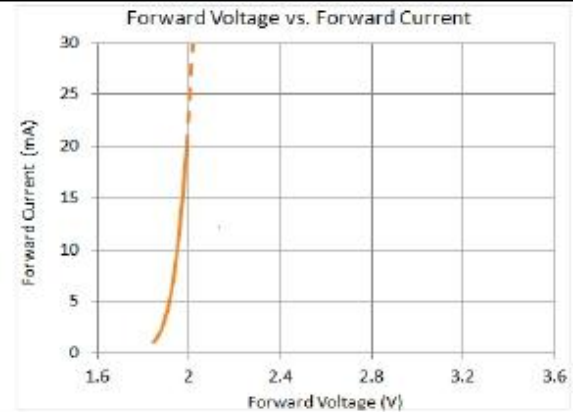
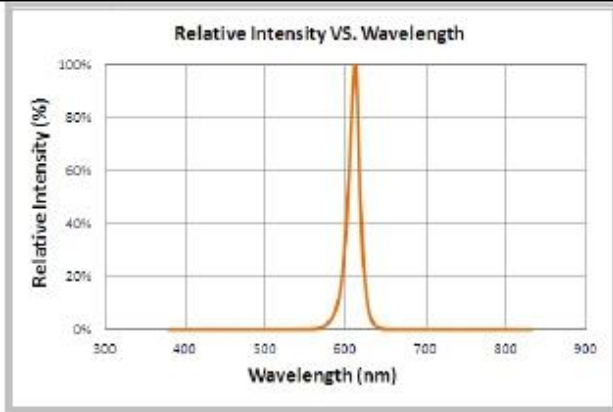

Directive Characteristics

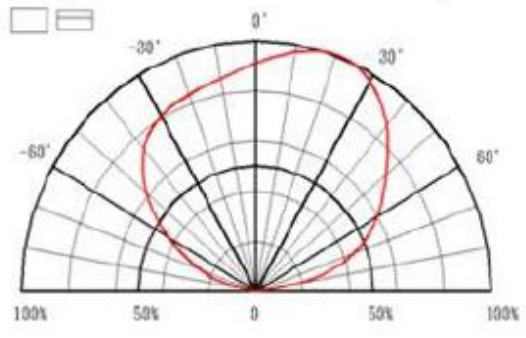

Directive Characteristics

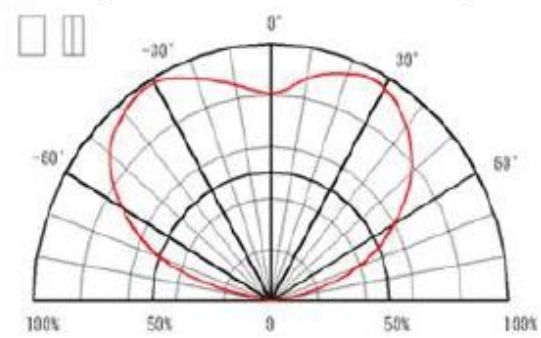

Drawing No.	*Rev.	Date	Page
BA0402A-ZON-020mA	B	2020/07/09	7/11

Packaging

Tape Dimension

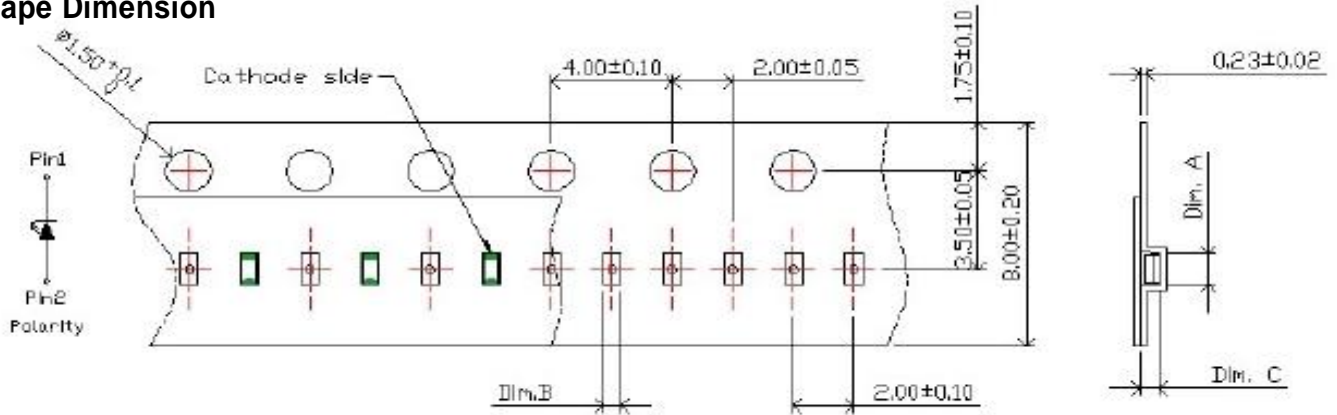

Dim. A	Dim. B	Dim. C	Q'ty/Reel
1.1 ± 0.05	0.6 ± 0.05	0.66 ± 0.05	4K

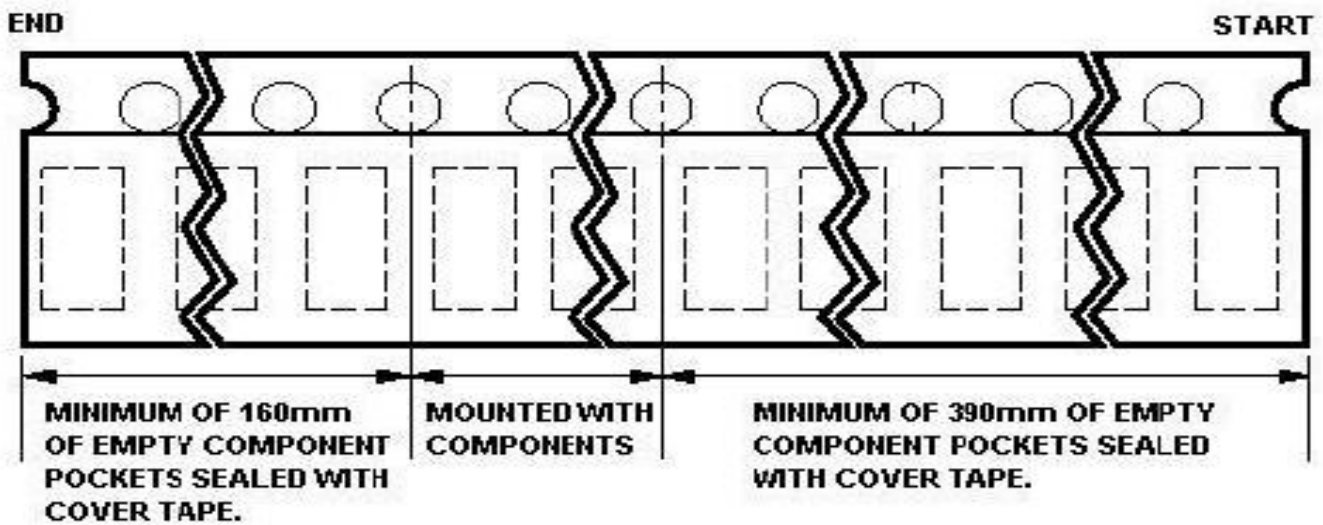

Drawing No.	*Rev.	Date	Page
BA0402A-ZON-020mA	B	2020/07/09	8/11

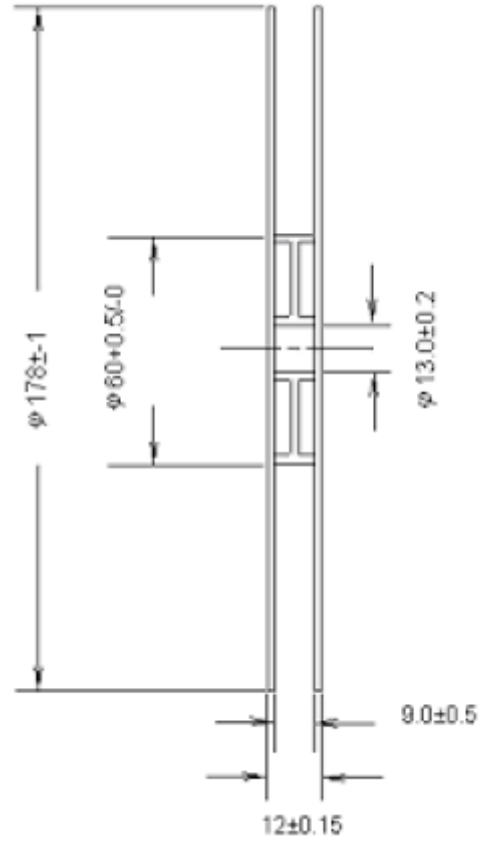
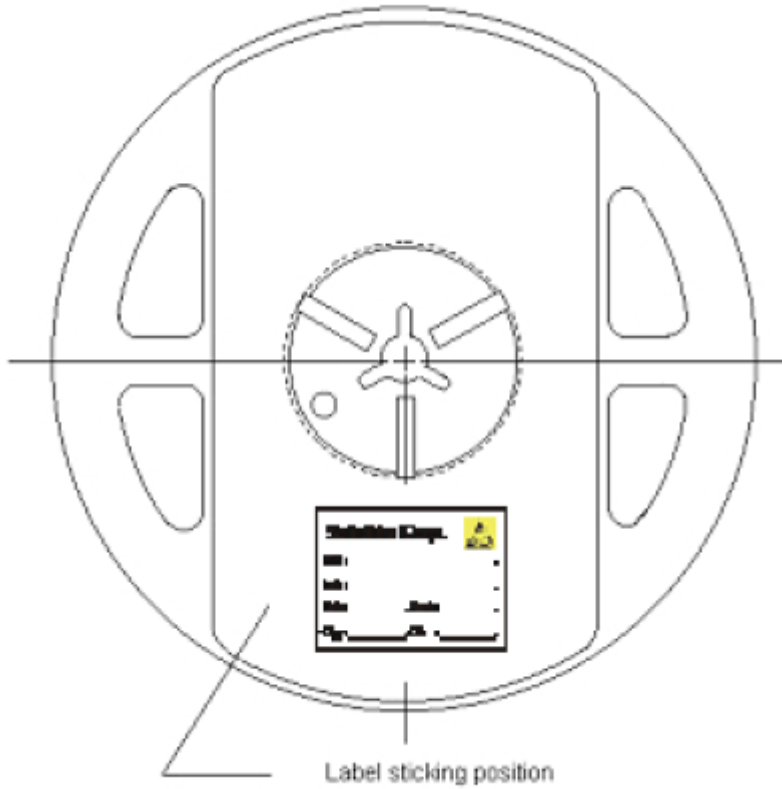

Packing

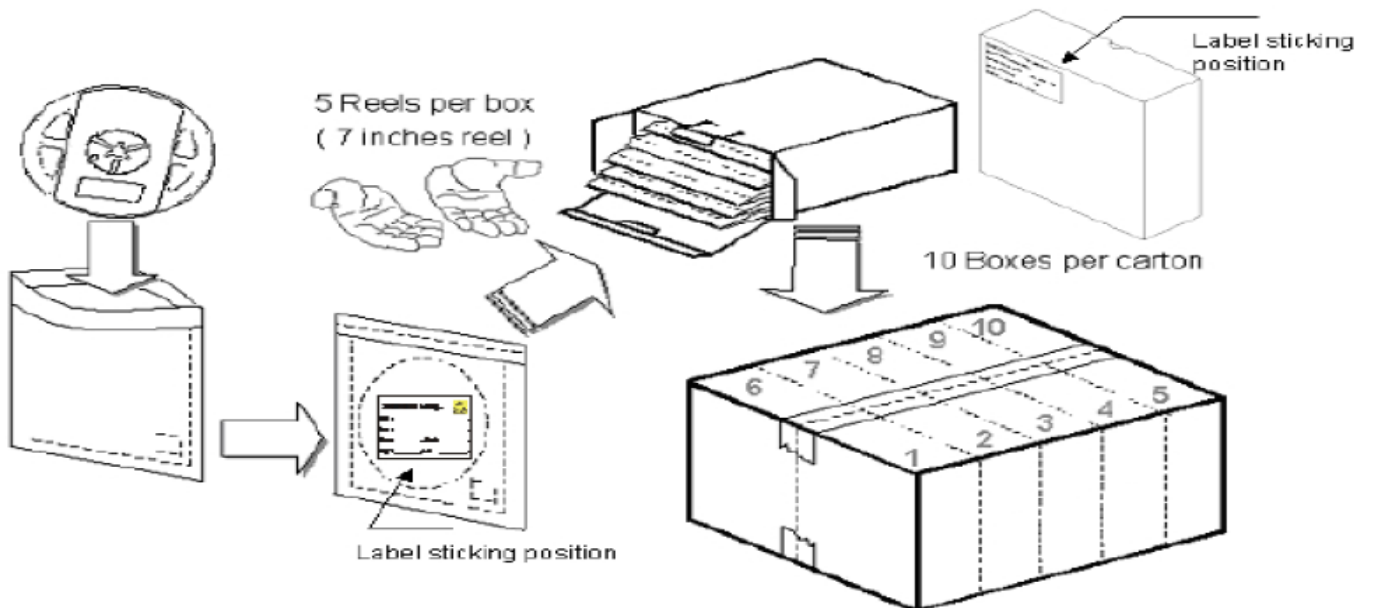

5 or 10 boxes per carton is available depending on shipment quantity

Dry Pack

All SMD optical devices are **MOISTURE SENSITIVE**. Avoid exposure to moisture at all times during transportation or storage. Every reel is packaged in a moisture protected anti-static bag. Each bag is properly sealed prior to shipment.

A humidity indicator will be included in the moisture protected anti-static bag prior to shipment.

The packaging sequence is as follows:

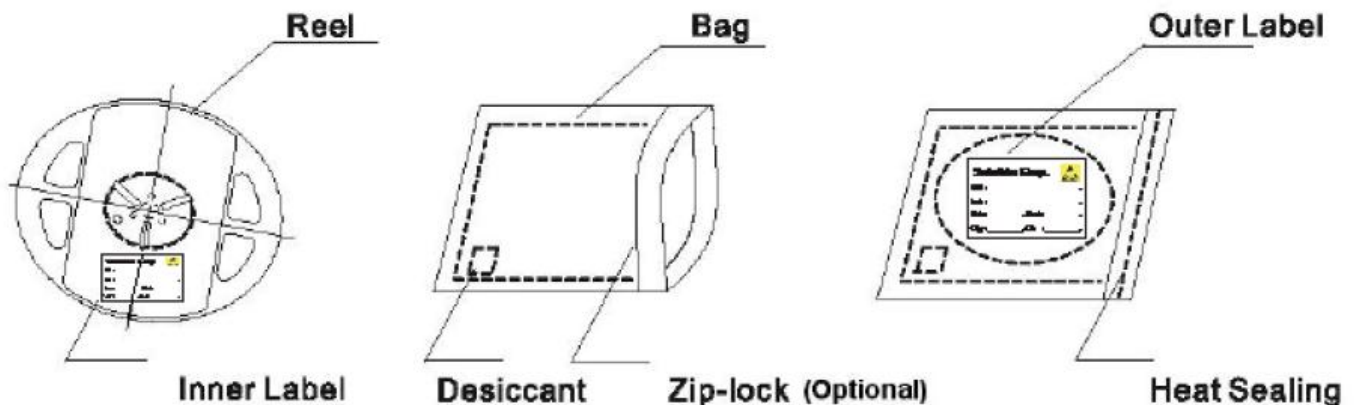

Baking

Baking before soldering is recommended when the package has been unsealed for 4 weeks.

The conditions are as followings:

1. $60\pm 3^{\circ}\text{C} \times (12\sim 24\text{hrs})$ and $<5\% \text{RH}$, taped reel type.
2. $100\pm 3^{\circ}\text{C} \times (45\text{min}\sim 1\text{hr})$, bulk type.
3. $130\pm 3^{\circ}\text{C} \times (15\text{min}\sim 30\text{min})$, bulk type.

Precautions

1. Avoid exposure to moisture at all times during transportation or storage.
2. Anti-Static precaution must be taken when handling GaN, InGaN, and AlInGaP products.
3. It is suggested to connect the unit with a current limiting resistor of the proper size. Avoid applying a reverse voltage beyond the specified limit.
4. Avoid operation beyond the limits as specified by the absolute maximum ratings.
5. Avoid direct contact with the surface through which the LED emits light.
6. If possible, assemble the unit in a clean room or dust-free environment.

Reflow Soldering

Recommend soldering paste specifications:

1. Operating temp.: Above 220 °C ,60 sec.
2. Peak temp.:260 °C Max.,10sec Max.
3. Reflow soldering should not be done more than two times.
4. Never attempt next process until the component is cooled down to room temperature after reflow.
5. The recommended reflow soldering profile (measured on the surface of the LED terminal) is as following:

Lead-free Solder Profile

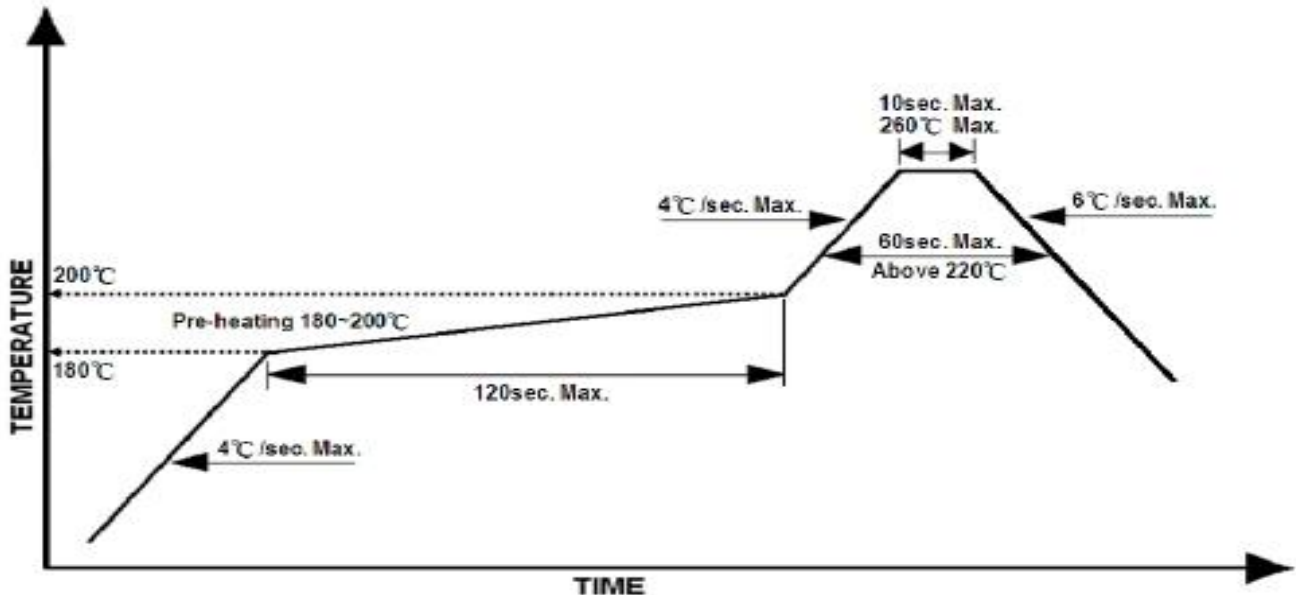

Reworking

- Rework should be completed within 5 seconds under 260°C.
- The iron tip must not come in contact with the copper foil.
- Twin-head type is preferred.

Cleaning

Following are cleaning procedures after soldering:

- An alcohol-based solvent such as isopropyl alcohol (IPA) is recommended.
- Temperature x Time should be 50°C x 30sec. or <30°C x 3min
- Ultrasonic cleaning: < 15W/ bath; bath volume ≤ 1liter
- Curing: 100°C max, <3min



Drawing No.	*Rev.	Date	Page
BA0402A-ZON-020mA	B	2020/07/09	11/11

Cautions of Pick and Place

- Avoid stress on the resin at elevated temperature.
- Avoid rubbing or scraping the resin by any object.
- Electric-static may cause damage to the component. Please ensure that the equipment is properly grounded. Use of an ionizer fan is recommended.